

radino 32 DW1000

The In-Circuit radino 32 DW1000 combines an STM32L1 with the DW1000 RF Transceiver in a small form-factor EMC-compliant module.

It's part of the radino-series, which provides full-Arduino-compatible wireless communication devices in a small form factor, all pin-compatible to each other.

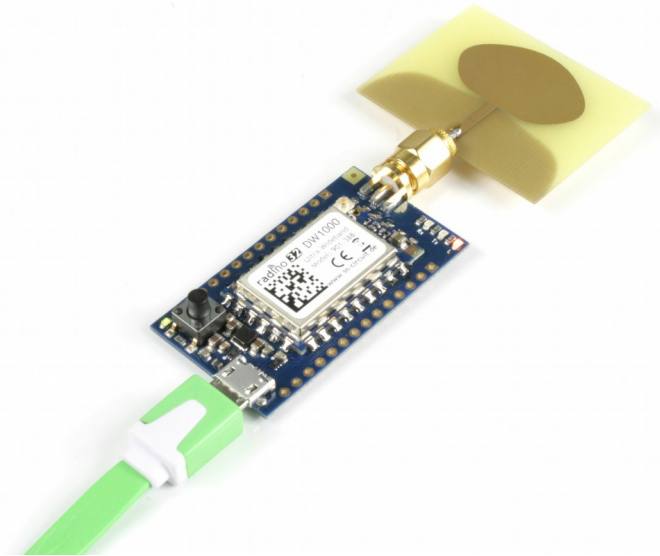

Features

- Arduino-compatible
- UWB Transceiver DW1000 connected internally
- IEEE802.15.4-2011 UWB compliant
- Supports high tag densities in RTLS
- STM32L151CC by STMicroelectronics with 32-bit ARM® Cortex®-M3 CPU
- 256 kbyte Flash, 32 kbyte RAM, 8 kbyte EEPROM
- Low Power RTC
- 12 bit ADC and DAC
- Capacitive touch sensing supported
- 23 multifunctional GPIOs (14 PWM, 10 ADC IN, 1 DAC OUT)
- USB, I²C, SPI, 2xUSART

Applications

- Precision real time location systems (RTLS) using two-way ranging or TDOA schemes in a variety of markets:
 - Healthcare
 - Consumer
 - Industrial
 - Other
- Location aware wireless sensor networks



For more information visit:
<http://www.in-circuit.de/>
<http://www.radino.cc/>

Overview

The In-Circuit radino 32 DW1000 combines an STM32L151 with the DW1000 RF Transceiver. Despite its small form factor, the radino 32 DW1000 offers great connectivity. Many GPIOs and interfaces (USB, I²C, SPI, 2xUSART) of the STM32L151 can be connected to external circuitry.

With our Arduino Library the radino 32 DW1000 becomes fully Arduino-compatible, which enables easy programming, using the Arduino IDE (<http://www.arduino.cc/>).

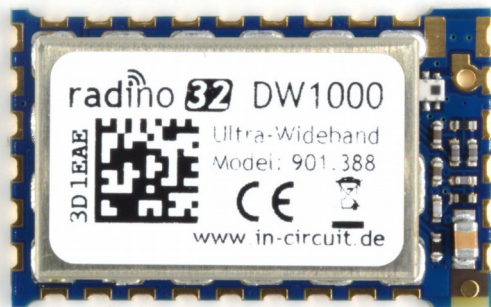

Micro Controller Section common to all radino 32 modules

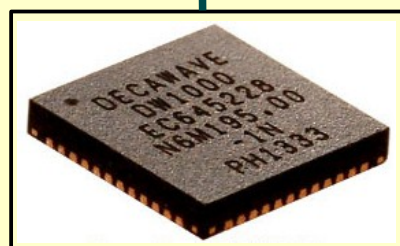
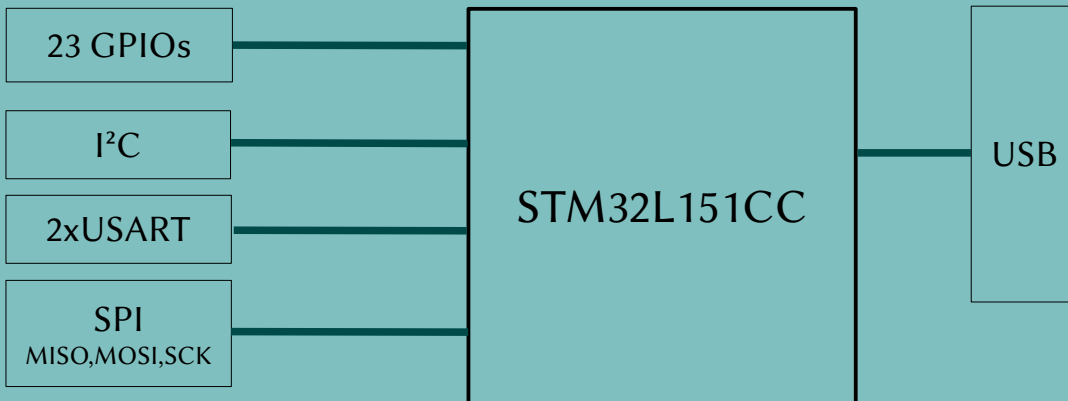

Radio Section – DW1000

radino 32 Pinout

Connected to internal radio section:

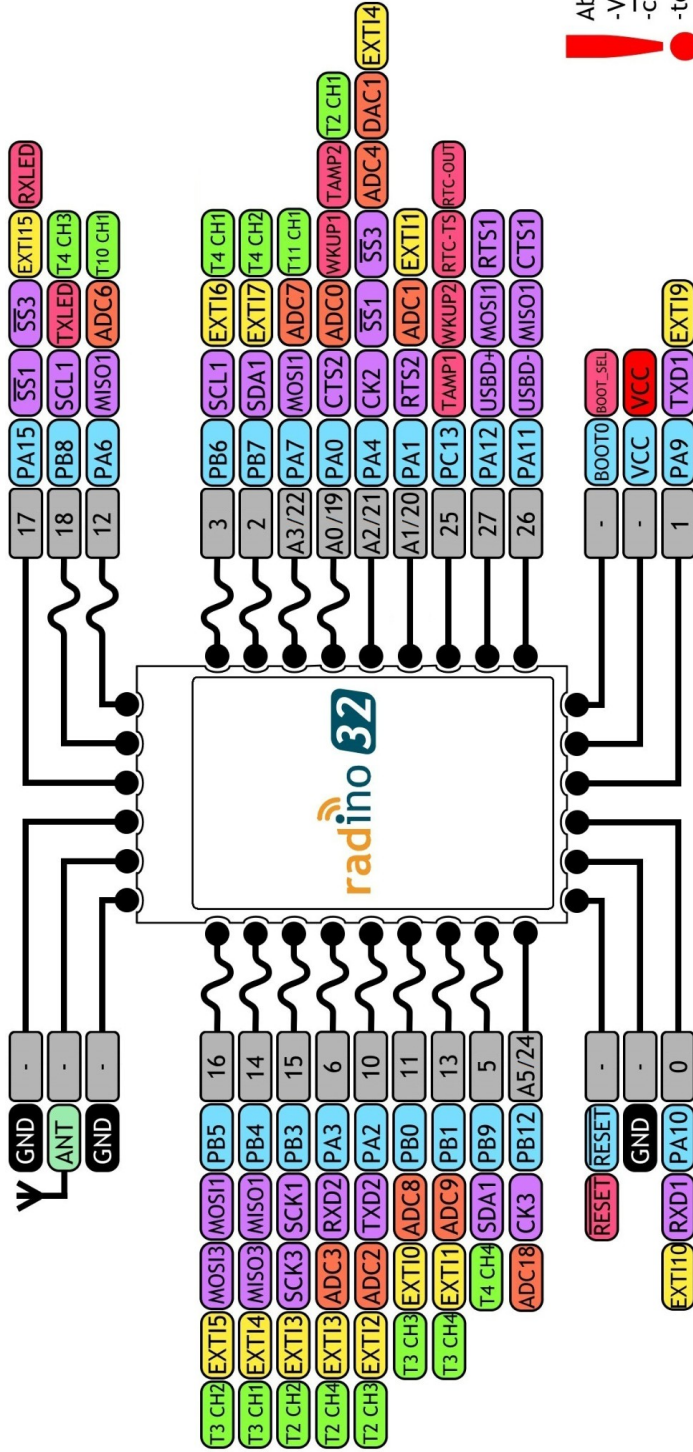
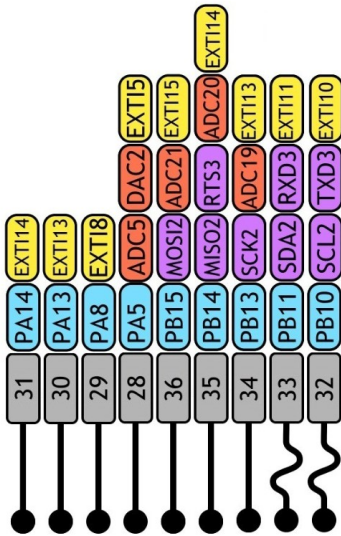

Legend for pin colors and functions:

- Power (Red)
- GND (Black)
- Arduino Pin (Grey)
- STM Port (Light Blue)
- Timer Channel (Light Green)
- Serial Pin (Purple)
- Analog Pin (Orange)
- Interrupt Pin (Yellow)
- Control Pin (Pink)
- Antenna (Light Green)
- PWM Pin (Black with wavy line)

! Absolute max. ratings:
 -VCC: max. 3.6V
 -current per Pin max. 20mA
 -total I/O current max. 60mA

Pinout and Terminal Description



Top View

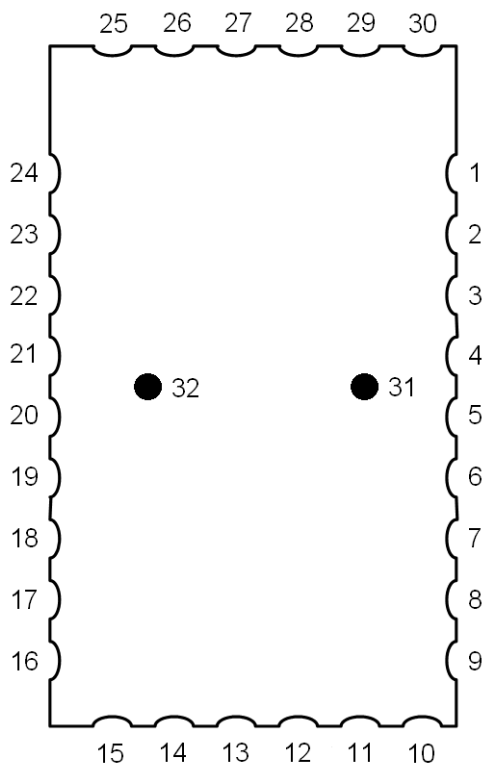
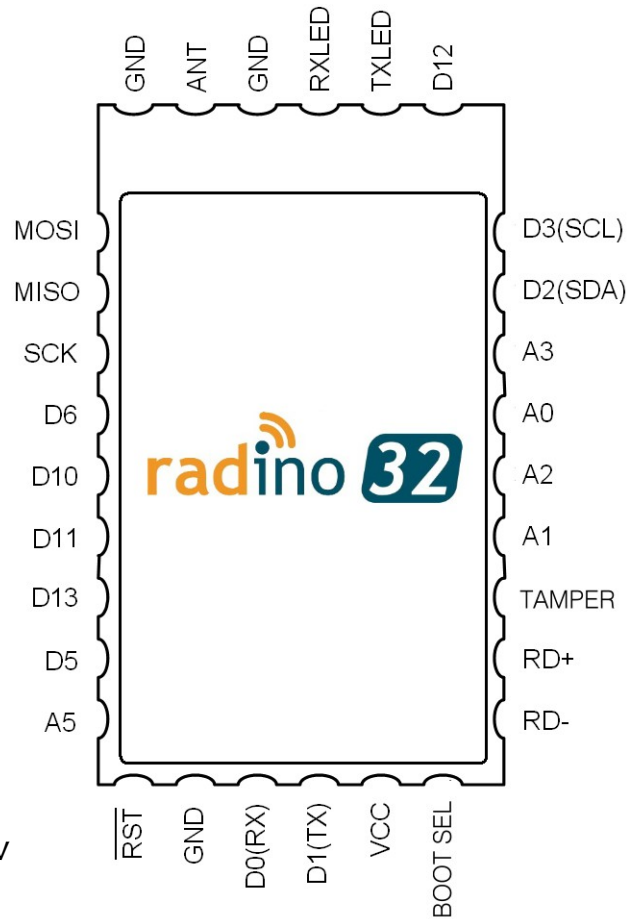

Bottom View

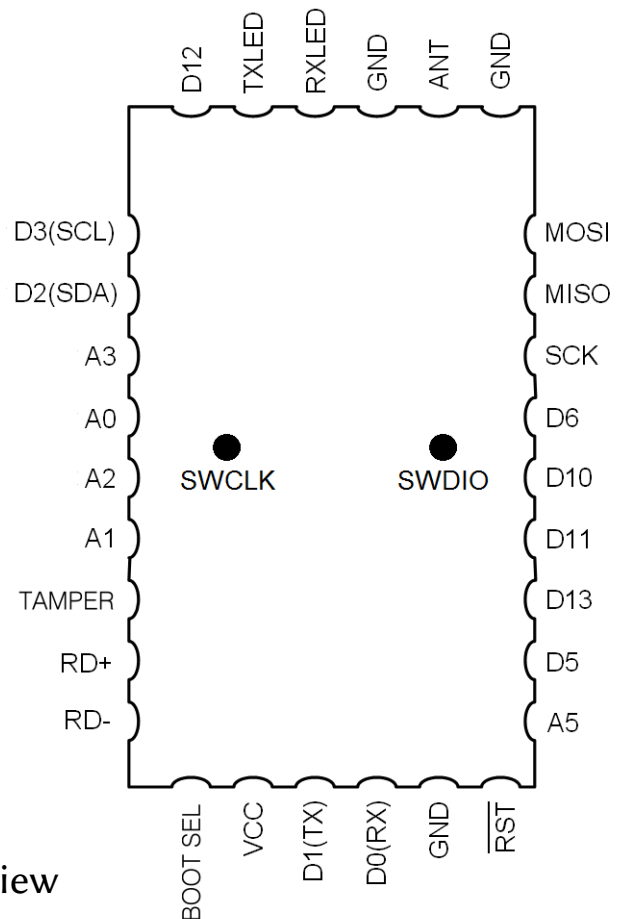

| radino Pin No. | Name | Arduino Pin No. | STM32L151 CC Port | Description / Function (bold = main function) |
|----------------|-----------------|-----------------|-------------------|--|
| 1 | MOSI | 16 | PB5 | SPI1-MOSI SPI3-MOSI; I2C1-SMBA; PWM; TIM3-CH2; EXTI5; GPIO |
| 2 | MISO | 14 | PB4 | SPI1-MISO SPI3-MISO; PWM; TIM3-CH1; EXTI4(shared with P20); GPIO |
| 3 | SCK | 15 | PB3 | SPI1-SCK SPI3-SCK; PWM; TIM2-CH2; EXTI3 (shared with P4); GPIO |
| 4 | D6 | 6 | PA3 | GPIO; USART2-RX PWM; TIM2-CH4; ADC3; OPAMP1-VOUT; EXTI3 (shared with P3) |
| 5 | D10 | 10 | PA2 | GPIO; USART2-TX; PWM; TIM2-CH3; ADC2; OPAMP1-VINM; EXTI2 |
| 6 | D11 | 11 | PB0 | GPIO; PWM; TIM3-CH3; ADC8; OAMP2-VOUT; EXTI0 |
| 7 | D13 | 13 | PB1 | GPIO; PWM; TIM3-CH4; ADC9; EXTI1 (shared with P19) |
| 8 | D5 | 5 | PB9 | GPIO; I2C-SDA; PWM; TIM4-CH4; |
| 9 | A5 | A5 24 | PB12 | ADC18; USART3-CK; SPI2-NSS; GPIO; |
| 10 | Reset | - | NRST | Reset of STM32L151CC |
| 11 | GND | - | VSS | Ground |
| 12 | D0(RX) | 0 | PA10 | USART1-RX ; EXTI10; GPIO |
| 13 | D1(TX) | 1 | PA9 | USART1-TX ; EXTI9; GPIO |
| 14 | V _{CC} | - | VCC | Power supply |
| 15 | BOOT_SELECT | - | BOOT0 | Boot Select |
| 16 | RD- | 26 | PA11 | USB-D- ; USART1-CTS; SPI1-MISO; GPIO |
| 17 | RD+ | 27 | PA12 | USB-D+ ; USART1-RTS; SPI1-MOSI; GPIO |
| 18 | TAMPER | 25 | PC13-WKUP2 | RTC-TAMP1; WKUP2; RTC-TS; RTC-OUT; GPIO |
| 19 | A1 | A1 20 | PA1 | ADC1; USART2-RTS; OAMP1-VINP; EXTI1(shared with P7); GPIO |
| 20 | A2 | A2 21 | PA4 | ADC4; DAC1; USART2-CK; SPI1-NSS; SPI3-NSS; EXTI4(shared with P4); GPIO |
| 21 | A0 | A0 19 | PA0-WKUP1 | ADC0; USART2-CTS; WKUP1; RTC-TAMP2; PWM; TIM2-CH1; GPIO |
| 22 | A3 | A3 22 | PA7 | ADC7; SPI1-MOSI; PWM; TIM11-CH1; OPAMP2-VINM; GPIO |
| 23 | D2(SDA) | 2 | PB7 | I2C1-SDA ; USART1-RX; PWM; TIM4-CH2; EXTI7; GPIO |
| 24 | D3(SCL) | 3 | PB6 | I2C1-SCL ; USART1-TX; PWM; TIM4-CH1; EXTI6; GPIO |
| 25 | D12 | 12 | PA6 | GPIO; SPI1-MISO; PWM; TIM10-CH1; OPAMP2-VINP; ADC6 |

| radino Pin No | Name | Arduino Pin No. | STM32L151 CC Port | Description / Function (bold = main function) |
|---------------|-----------|-----------------|-------------------|--|
| 26 | TXLED | 18 | PB8 | TXLED ; I2C1-SCL; PWM; TIM4-CH3; GPIO |
| 27 | RXLED | 17 | PA15 | RXLED ; SPI1-NSS; SPI3-NSS; EXTI15; GPIO |
| 28 | GND | - | VSS | Ground |
| 29 | ANTENNA | - | - | Antenna pin |
| 30 | GND | - | VSS | Ground |
| 31 | SWDIO | 30 | PA13 | SWDIO of STM32L151CC (pad on bottom) |
| 32 | SWCLK | 31 | PA14 | SWCLK of STM32L151CC (pad on bottom) |
| - | RF_MISO | 35 | PB14 | connected to internal radio section Signal: MISO |
| - | RF_MOSI | 36 | PB15 | connected to internal radio section Signal: MOSI |
| - | RF_SCK | 34 | PB13 | connected to internal radio section Signal: CLK |
| - | RF_SS | 29 | PA8 | connected to internal radio section Signal: \overline{CS} , 100k pullup attached on board |
| - | RF_RST | 28 | PA5 | connected to internal radio section Signal: \overline{RST} |
| - | RF_WAKEUP | 32 | PB10 | connected to internal radio section Signal: WAKEUP |
| - | RF_IRQ | 33 | PB11 | connected to internal radio section Signal: IRQ, 100k pulldown attached on board |

Detailed Interconnection diagram

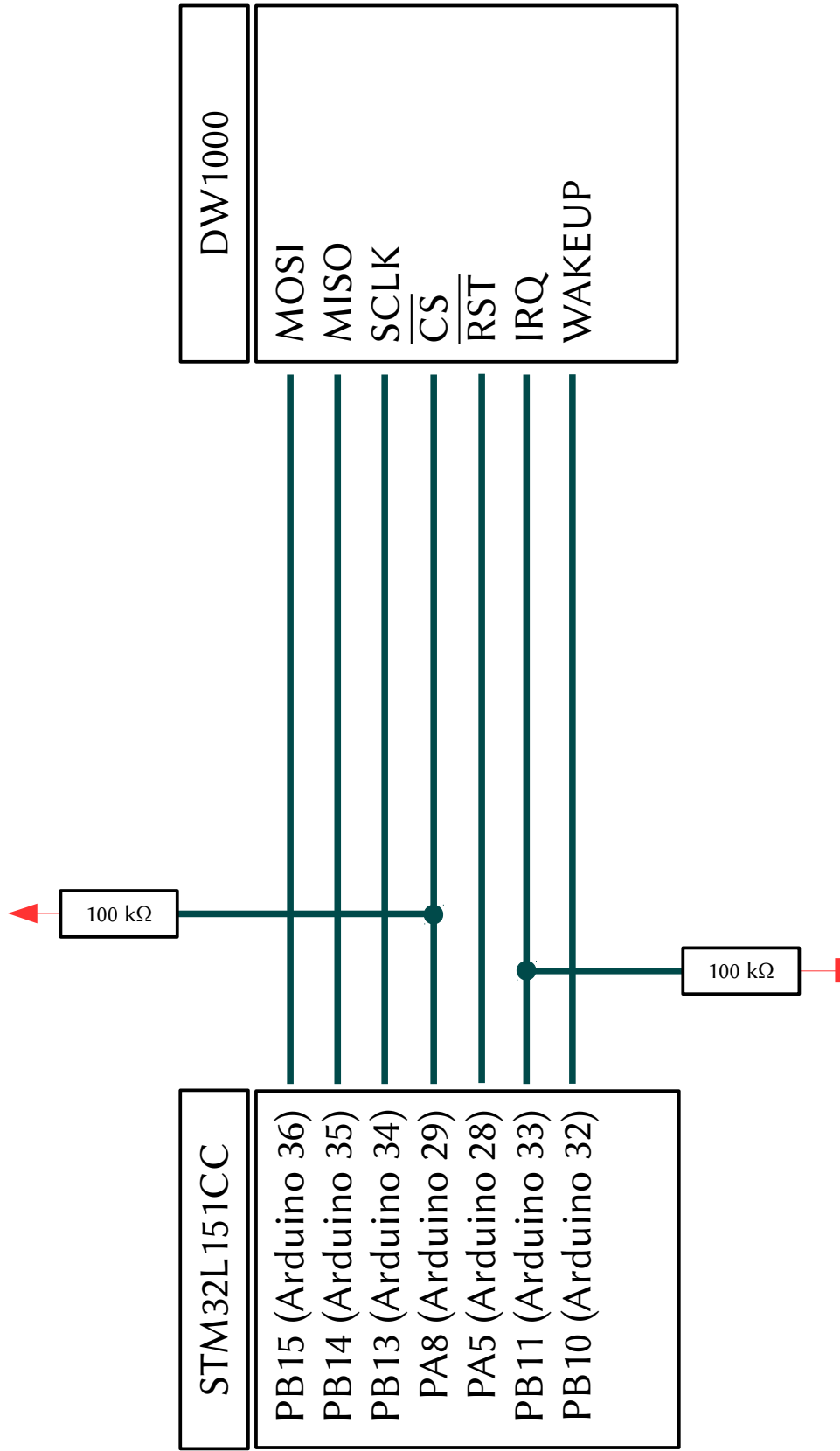

Electrical Characteristics

Absolut Maximum Ratings

Note: These are absolute maximum ratings beyond which the module can be permanently damaged. These are not maximum operating conditions.

| Rating | Min | Max | Unit |
|---------------------------------|------|-----|------|
| Storage Temperature | -40 | 125 | °C |
| V_{CC} | -0.3 | 3.6 | V |
| Current per IO | | 20 | mA |
| Total Current by sum of all IOs | | 60 | mA |

Recommended Operating Conditions

Environmental conditions

| Rating | Min | Typ. | Max | Unit |
|-----------------------|-----|------|-----|------|
| Operating Temperature | -40 | | 85 | °C |
| V_{CC} | 2.8 | 3.3 | 3.6 | V |

DC Characteristics

$T_A = -40^{\circ}\text{C}$ to 85°C , $V_{CC} = 2.7\text{V}$ to 3.6V (unless otherwise noted)

| Symbol | Rating | Min | Typ. | Max | Unit |
|-----------|---|-------------|------|----------------|------|
| V_{BS} | BOOT_SELECT Voltage | 0 | | 5.5 | V |
| V_{IL} | Input Low Voltage, | -0.3 | | $0.2V_{CC}$ | V |
| V_{IH1} | Input High Voltage, Pins: P4, P6, P7, P20 | $0.9V_{CC}$ | | $V_{CC} + 0.3$ | V |
| V_{IH2} | Input High Voltage, all other Pins | $0.9V_{CC}$ | | 5.25 | V |
| V_{OL} | Output Low Voltage | | | 0.5 | V |
| V_{OH} | Output High Voltage | $0.9V_{CC}$ | | | V |

Current consumption parameters

Operation conditions: $V_{CC}=3.3V$, $T_A=-40^{\circ}C$ to $+85^{\circ}C$.

| Symbol | Rating | Min | Typ. | Max | Unit |
|----------|--|-----|------|-----|---------|
| I_{on} | Full on | --- | 73 | --- | mA |
| I_{s2} | Standby without RTC (DW1000: power down mode; STM: Standby mode, RTC disabled, wakeup by radino pin 18 or 21) | --- | 1.5 | --- | μA |

Package Dimensions and recommended PCB Footprint

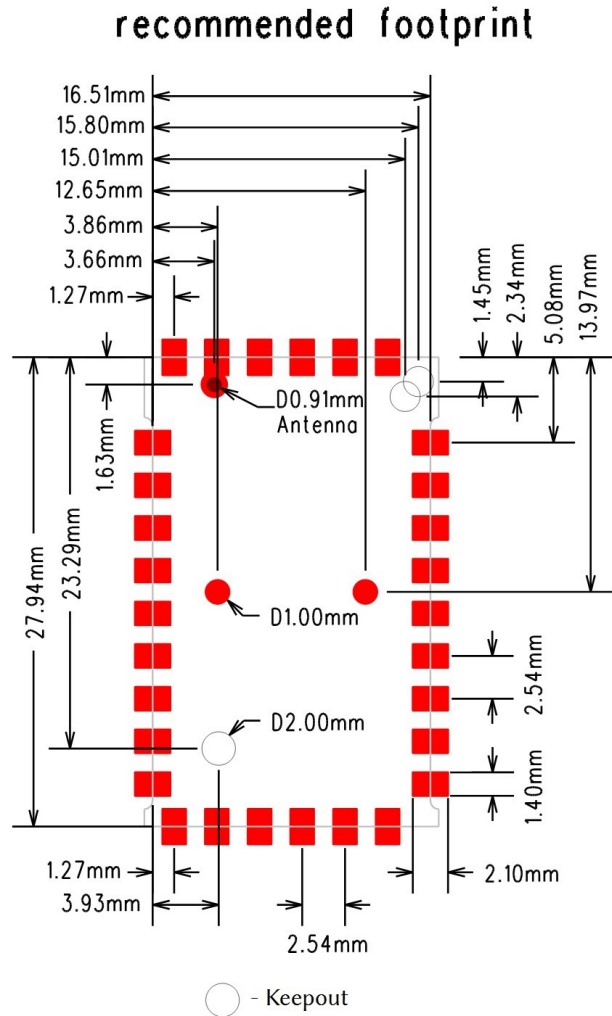
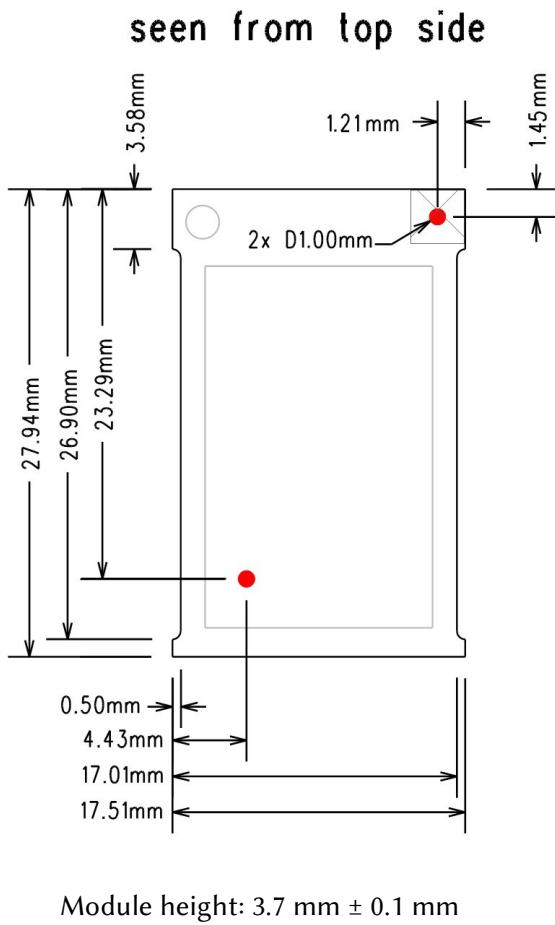

Packaging: tape & reel specification

All radino modules come in a tape & reel package suitable for pick and place machines. Small quantities are delivered as cut-tape. There are 2 kinds of reels available with 100pcs and 500pcs per reel (see section ordering information)
Except the number of modules, all parameters are same to both reel sizes:

- 13" reel size
- 44mm tape width
- tape pocket dimensions 29mm x 19mm x 4mm
- module spacing 24mm
- 2mm hole in the middle of the module body
- 1.5mm tape holes for transport

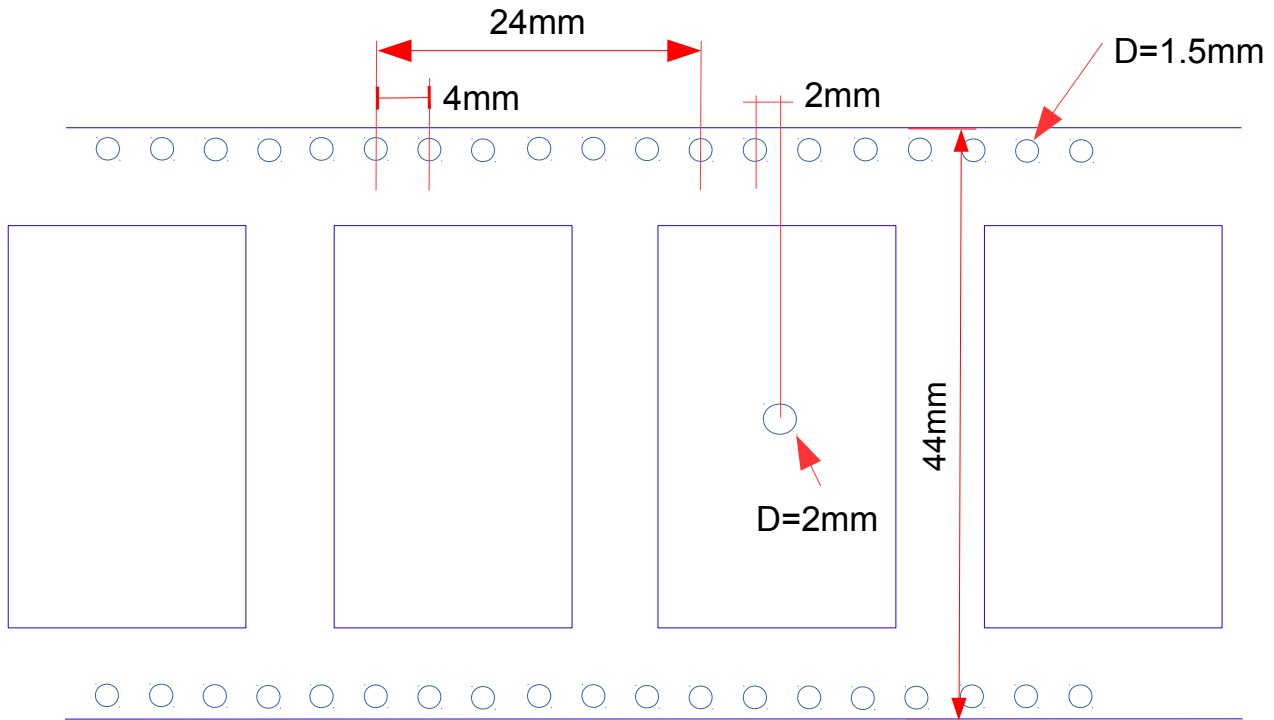

Transport direction
(Antenna connector to the right)

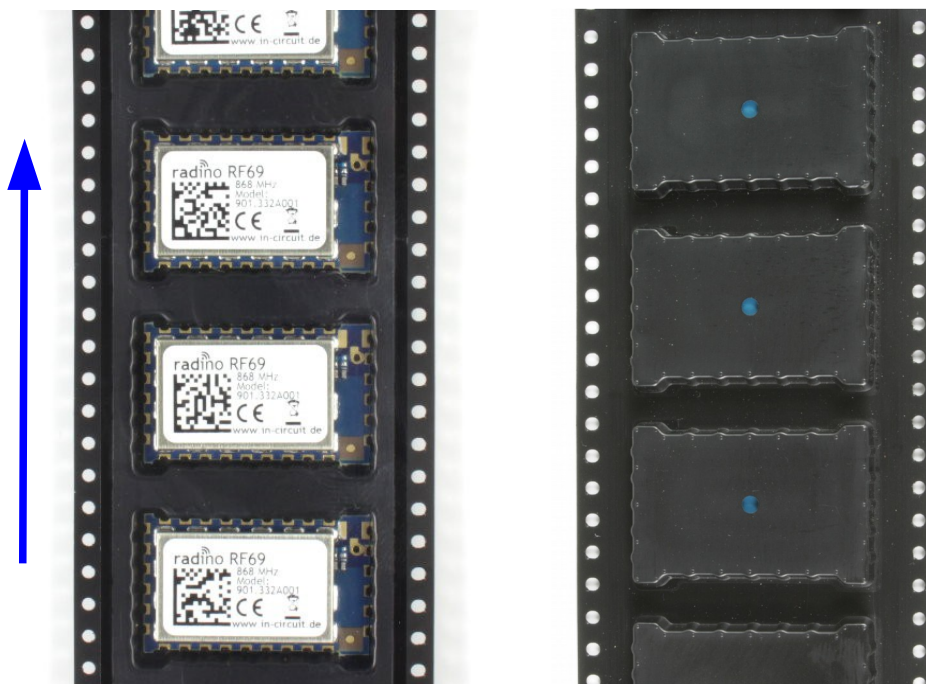

Reflow temperature profile

The single most critical stage in the automated assembly process is the reflow stage. The reflow profile shall not exceed the following maximum ratings:

- heating gradients $<3^{\circ}\text{C}/\text{sec}$
- peak zone temperature of the module $<245^{\circ}\text{C}$
- time in peak zone <40 sec.
- time above 220°C <80 sec.

Excessive temperatures, transport times and shocks during the reflow process **MUST** not be applied to the module.

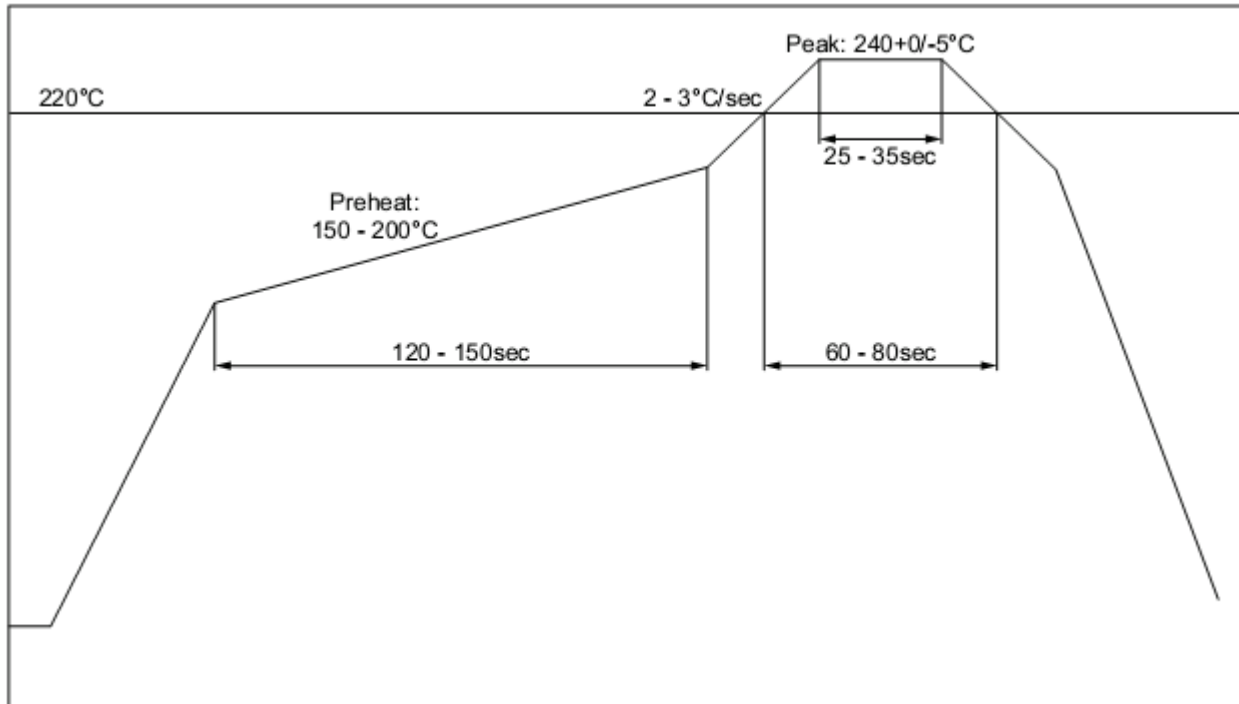

Recommended reflow temperature profile

Washability

The radino modules are wash-resistant, but are not sealed. In-Circuit recommends manufacturing without washing. If washing is needed make sure that a drying time is provided to the modules before applying electrical power. The drying time should be sufficient to allow any moisture that may have migrated into the module to evaporate, thus eliminating the potential for shorting damage during power-up or testing.

If the wash contains contaminants, the performance may be adversely affected, even after drying.

Ordering Information

| Part | Ordering Code | MOQ | Package |
|-----------------|---------------|-----|-------------------------|
| radino32 DW1000 | 901.388 | 1 | Cut Tape, Reels 100/500 |

All radino modules are available online: <http://www.radino.cc/>

Certifications



European R&TTE Directive Statements

The radino32 DW1000 module has been tested and found to comply with Annex IV of the R&TTE Directive 1999/5/EC and is subject of a notified body opinion. The module has been approved for Antennas with gains of 2 dBi or less.



RoHS / WEEE compliant

WEEE-Reg.-Nr. DE 17225017



FCC
pending

Revision history:

| Version | Date | Changes | Editor |
|---------|------------|------------------------------|--------|
| A | 2016/02/01 | | Träger |
| | 2016/09/13 | Fix pulldown from RST to IRQ | Grünig |
| | 2017/01/23 | Major Update | Grünig |