

radino 32 SX1272

The In-Circuit radino 32 SX1272 combines an **STM32L1** with the **SX1272** RF Transceiver in a small form-factor **EMC-compliant** module.

It's part of the radino-series, which provides full-Arduino-compatible wireless communication devices in a small form factor, all **pin-compatible** to each other.

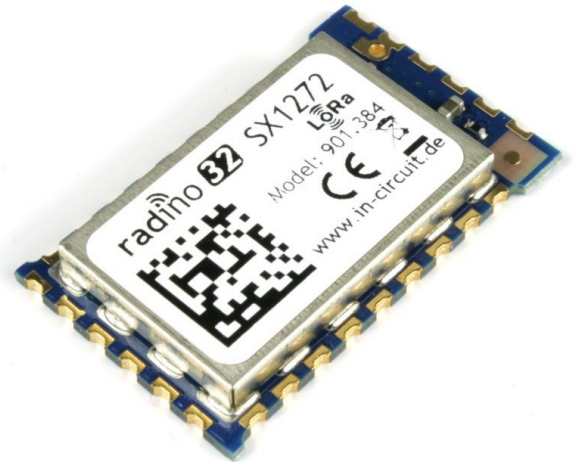

Features

- Arduino-compatible
- RF Transceiver SX1272 connected internally
<http://www.semtech.com/images/datasheet/sx1272.pdf>
- Available for 868MHz /915MHz
- STM32L151CC by STMicroelectronics with 32-bit ARM® Cortex®-M3 CPU
- 256 kbyte Flash, 32 kbyte RAM, 8 kbyte EEPROM
- Low Power RTC
- 12 bit ADC and DAC
- 23 multifunctional GPIOs (14 PWM, 10 ADC IN, 1 DAC OUT)
- USB, I²C, SPI, 2xUSART

Applications

- Ultra low power wireless applications operating in the 868/915 MHz ISM/SRD bands
- Automated Meter Reading
- Home and Building Automation
- Wireless Alarm and Security Systems
- Industrial Monitoring and Control
- Long range Irrigation Systems

For more information visit:
<http://www.in-circuit.de/>
<http://www.radino.cc/>

Overview

The In-Circuit radino 32 SX1272 combines an STM32L151 with the SX1272 RF Transceiver. Despite its small form factor, the radino 32 SX1272 offers great connectivity. Many GPIOs and interfaces (USB, I²C, SPI, 2xUSART) of the STM32L151 can be connected to external circuitry.

With our Arduino Library the radino 32 SX1272 becomes fully Arduino-compatible, which enables easy programming, using the Arduino IDE (<http://www.arduino.cc/>).

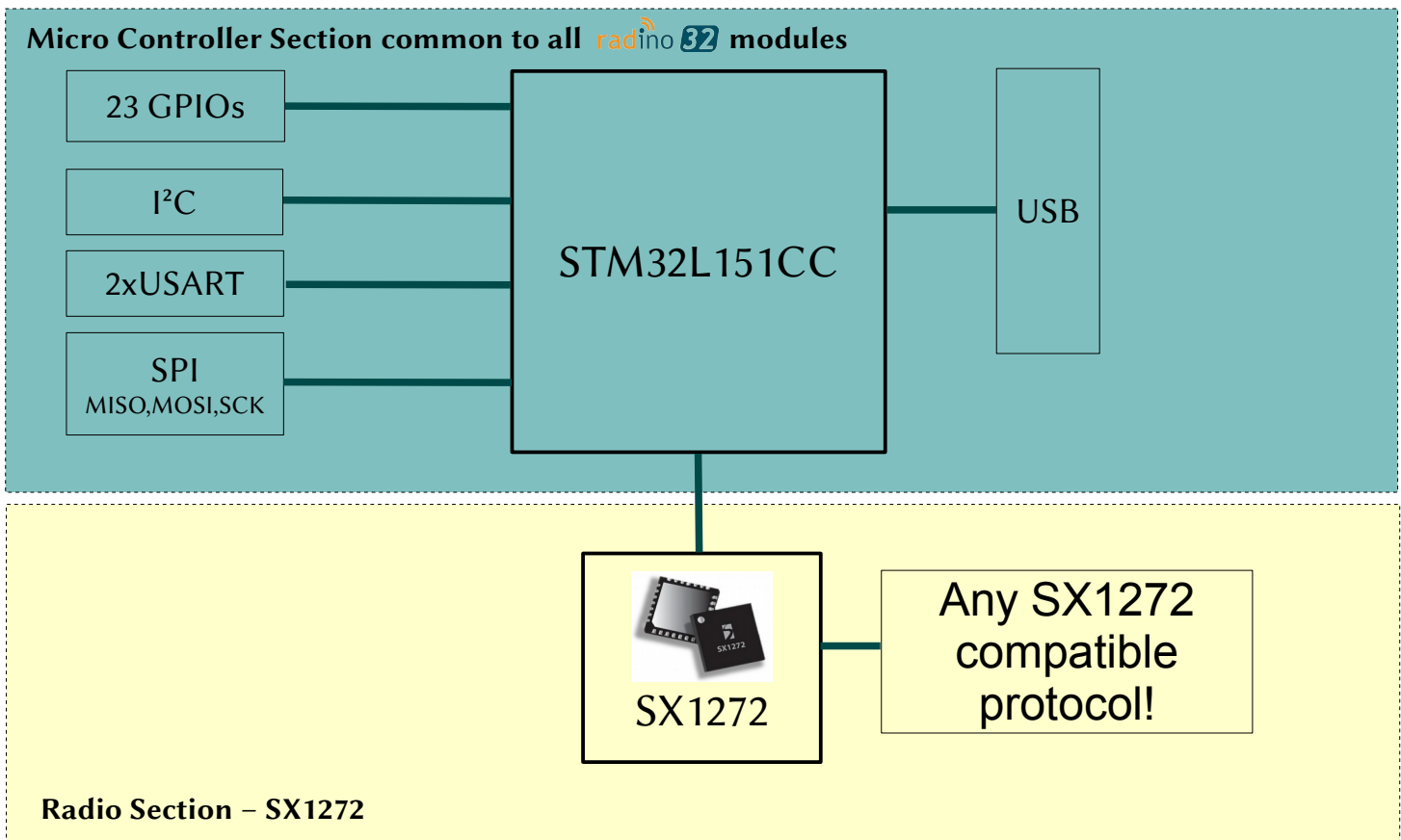

radino 32 Pinout

Connected to internal radio section:

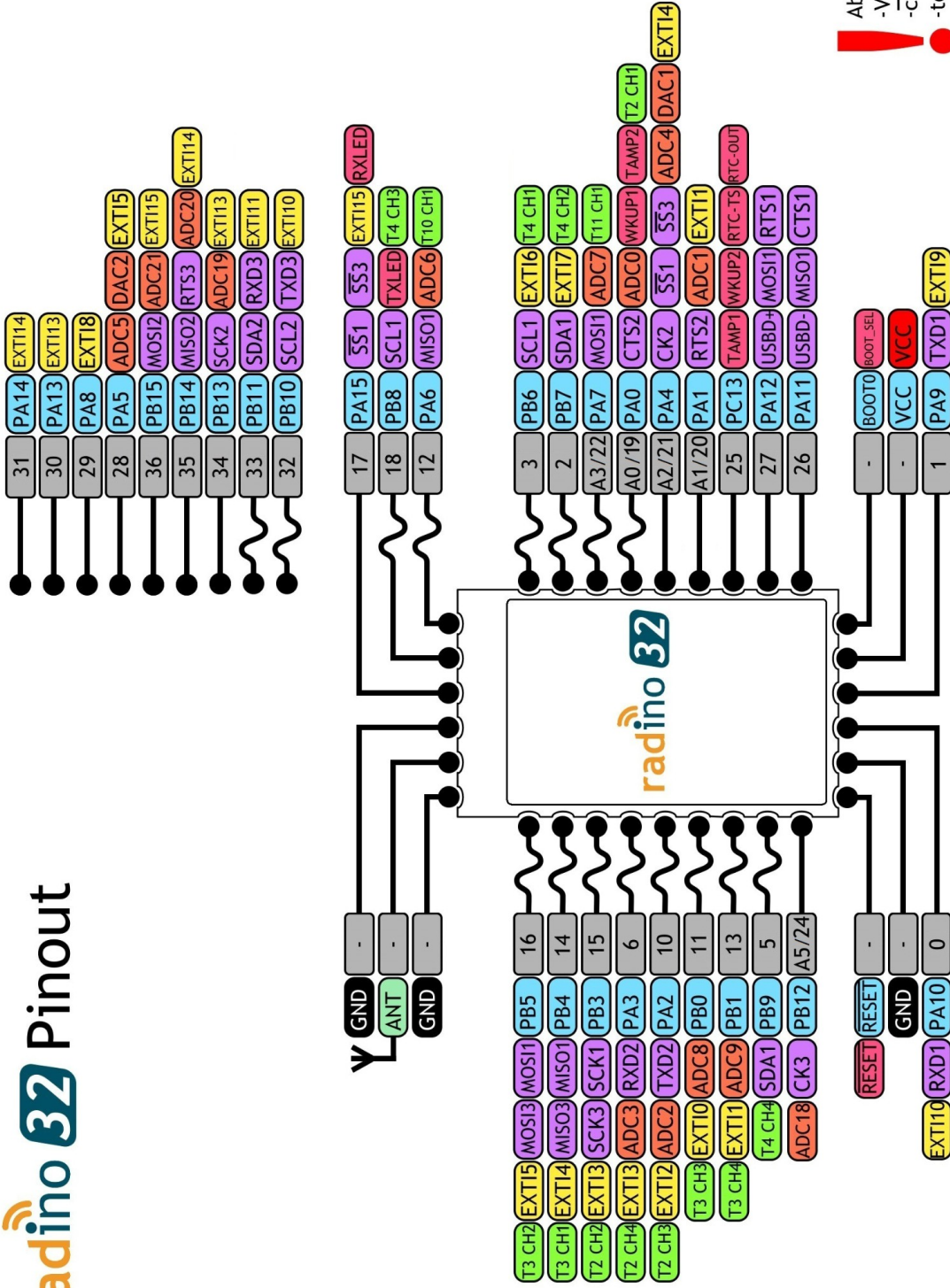

Pinout and Terminal Description



Top View

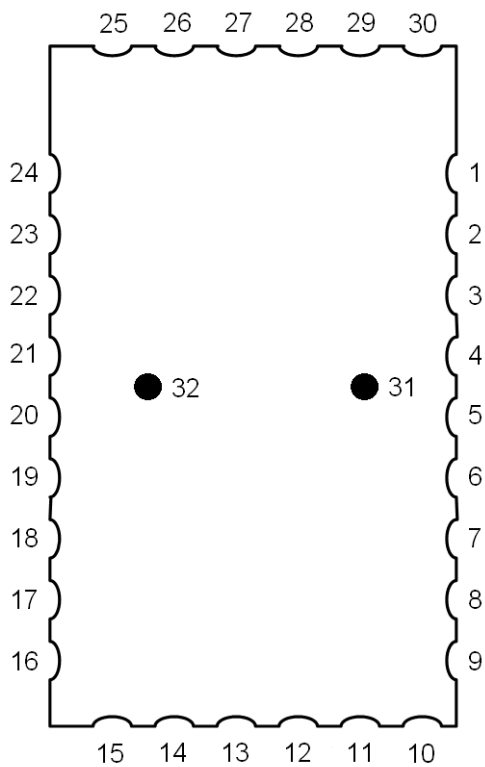
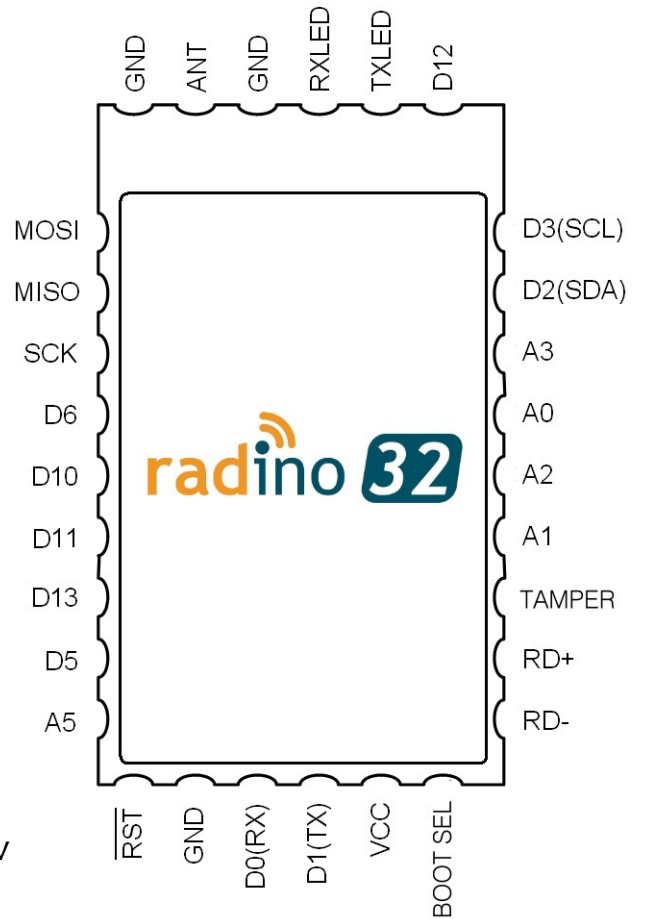

Bottom View

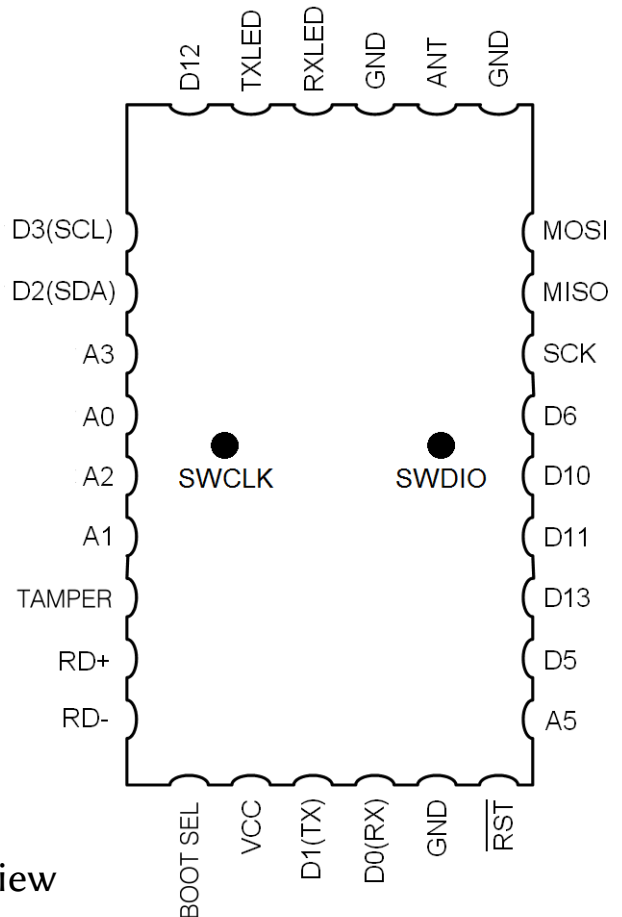

radino Pin No.	Name	Arduino Pin No.	STM32L151 CC Port	Description / Function (bold = main function)
1	MOSI	16	PB5	SPI1-MOSI SPI3-MOSI; I2C1-SMBA; PWM; TIM3-CH2; EXTI5; GPIO
2	MISO	14	PB4	SPI1-MISO SPI3-MISO; PWM; TIM3-CH1; EXTI4(shared with P20); GPIO
3	SCK	15	PB3	SPI1-SCK SPI3-SCK; PWM; TIM2-CH2; EXTI3 (shared with P4); GPIO
4	D6	6	PA3	GPIO; USART2-RX PWM; TIM2-CH4; ADC3; OPAMP1-VOUT; EXTI3 (shared with P3)
5	D10	10	PA2	GPIO; USART2-TX; PWM; TIM2-CH3; ADC2; OPAMP1-VINM; EXTI2
6	D11	11	PB0	GPIO; PWM; TIM3-CH3; ADC8; OAMP2-VOUT; EXTI0
7	D13	13	PB1	GPIO; PWM; TIM3-CH4; ADC9; EXTI1 (shared with P19)
8	D5	5	PB9	GPIO; I2C-SDA; PWM; TIM4-CH4;
9	A5	A5 24	PB12	ADC18; USART3-CK; SPI2-NSS; GPIO;
10	Reset	-	NRST	Reset of STM32L151CC
11	GND	-	VSS	Ground
12	D0(RX)	0	PA10	USART1-RX ; EXTI10; GPIO
13	D1(TX)	1	PA9	USART1-TX ; EXTI9; GPIO
14	V _{CC}	-	VCC	Power supply
15	BOOT_SELECT	-	BOOT0	Boot Select
16	RD-	26	PA11	USB-D- ; USART1-CTS; SPI1-MISO; GPIO
17	RD+	27	PA12	USB-D+ ; USART1-RTS; SPI1-MOSI; GPIO
18	TAMPER	25	PC13-WKUP2	RTC-TAMP1; WKUP2; RTC-TS; RTC-OUT; GPIO
19	A1	A1 20	PA1	ADC1; USART2-RTS; OAMP1-VINP; EXTI1(shared with P7); GPIO
20	A2	A2 21	PA4	ADC4; DAC1; USART2-CK; SPI1-NSS; SPI3-NSS; EXTI4(shared with P4); GPIO
21	A0	A0 19	PA0-WKUP1	ADC0; USART2-CTS; WKUP1; RTC-TAMP2; PWM; TIM2-CH1; GPIO
22	A3	A3 22	PA7	ADC7; SPI1-MOSI; PWM; TIM11-CH1; OPAMP2-VINM; GPIO
23	D2(SDA)	2	PB7	I2C1-SDA ; USART1-RX; PWM; TIM4-CH2; EXTI7; GPIO
24	D3(SCL)	3	PB6	I2C1-SCL ; USART1-TX; PWM; TIM4-CH1; EXTI6; GPIO
25	D12	12	PA6	GPIO; SPI1-MISO; PWM; TIM10-CH1; OPAMP2-VINP; ADC6

radino Pin No	Name	Arduino Pin No.	STM32L151 CC Port	Description / Function (bold = main function)
26	TXLED	18	PB8	TXLED ; I2C1-SCL; PWM; TIM4-CH3; GPIO
27	RXLED	17	PA15	RXLED ; SPI1-NSS; SPI3-NSS; EXTI15; GPIO
28	GND	-	VSS	Ground
29	ANTENNA	-	-	Antenna pin
30	GND	-	VSS	Ground
31	SWDIO	30	PA13	SWDIO of STM32L151CC (pad on bottom)
32	SWCLK	31	PA14	SWCLK of STM32L151CC (pad on bottom)
-	RF_MISO	35	PB14	connected to internal radio section Signal: MISO
-	RF_MOSI	36	PB15	connected to internal radio section Signal: MOSI
-	RF_SCK	34	PB13	connected to internal radio section Signal: SCK
-	RF_SS	29	PA8	connected to internal radio section Signal: \overline{SS}
-	RF_DIO0	31	PA14	connected to internal radio section Signal: DIO0
-	RF_DIO1	33	PB11	connected to internal radio section Signal: DIO1
-	RF_DIO2	30	PA13	connected to internal radio section Signal: DIO2
-	RF_DIO3	32	PB10	connected to internal radio section Signal: DIO3
-	RF_RST	28	PA5	connected to internal radio section Signal: RESET

Detailed Interconnection diagram

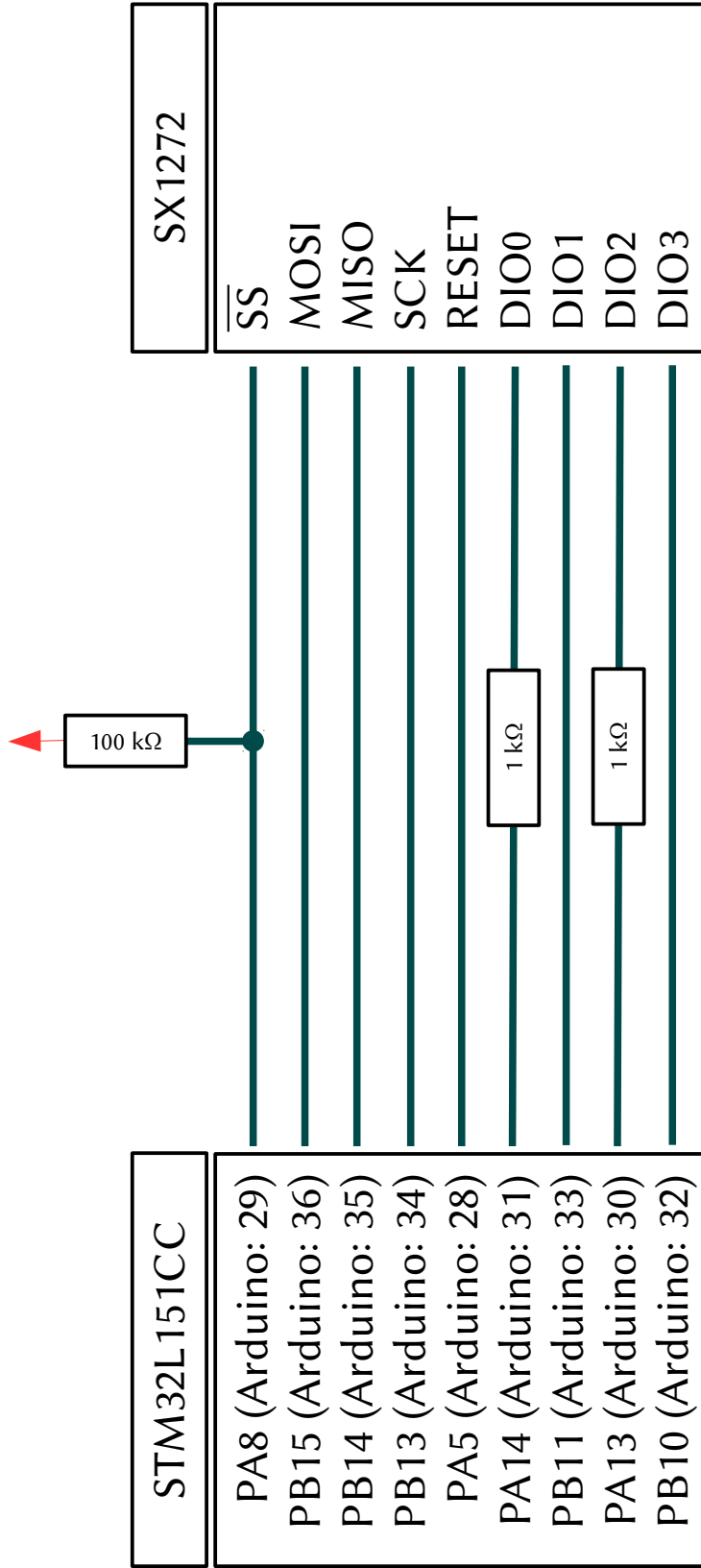

Electrical Characteristics

Absolut Maximum Ratings

Note: These are absolute maximum ratings beyond which the module can be permanently damaged. These are not maximum operating conditions.

Rating	Min	Max	Unit
Storage Temperature	-40	115	°C
V_{CC}	-0.5	3.9	V
Current per IO		20	mA
Total Current by sum of all IOs		60	mA

Recommended Operating Conditions

Environmental conditions

Rating	Min	Typ.	Max	Unit
Operating Temperature	-40		85	°C
V_{CC}	1.8	3.3	3.6	V

DC Characteristics

$T_A = -40^{\circ}\text{C}$ to 85°C , $V_{CC} = 2.7\text{V}$ to 3.6V (unless otherwise noted)

Symbol	Rating	Min	Typ.	Max	Unit
V_{BS}	BOOT_SELECT Voltage	0		5.5	V
V_{IL}	Input Low Voltage,	-0.3		$0.2V_{CC}$	V
V_{IH1}	Input High Voltage, Pins: P4, P6, P7, P20	$0.9V_{CC}$		$V_{CC} + 0.3$	V
V_{IH2}	Input High Voltage, all other Pins	$0.9V_{CC}$		5.25	V
V_{OL}	Output Low Voltage			0.5	V
V_{OH}	Output High Voltage	$0.9V_{CC}$			V

Current consumption parameters

Operation conditions: $V_{CC}=3.3V$, $T_A=-40^{\circ}C$ to $+85^{\circ}C$.

Symbol	Rating	Min	Typ.	Max	Unit
I_{LT}	Low-power transmit mode (SX1272: Low power transmit, $P_{out}=+7dBm$; STM: Low-power run mode)	---	18	---	mA
I_{HT}	High-power transmit mode (SX1272: High power transmit, $P_{out}=+20dBm$; STM: Low-power run mode)	---	125	---	mA
I_R	Receive mode (SX1272: Receive mode, LnaBosst Off; STM: Low-power run mode)	---	10.5	---	mA
I_S	Deep sleep mode (Sx1272: Sleep mode; STM: Standby mode, RTC disabled)	---	0.4	---	μA

Package Dimensions and recommended PCB Footprint

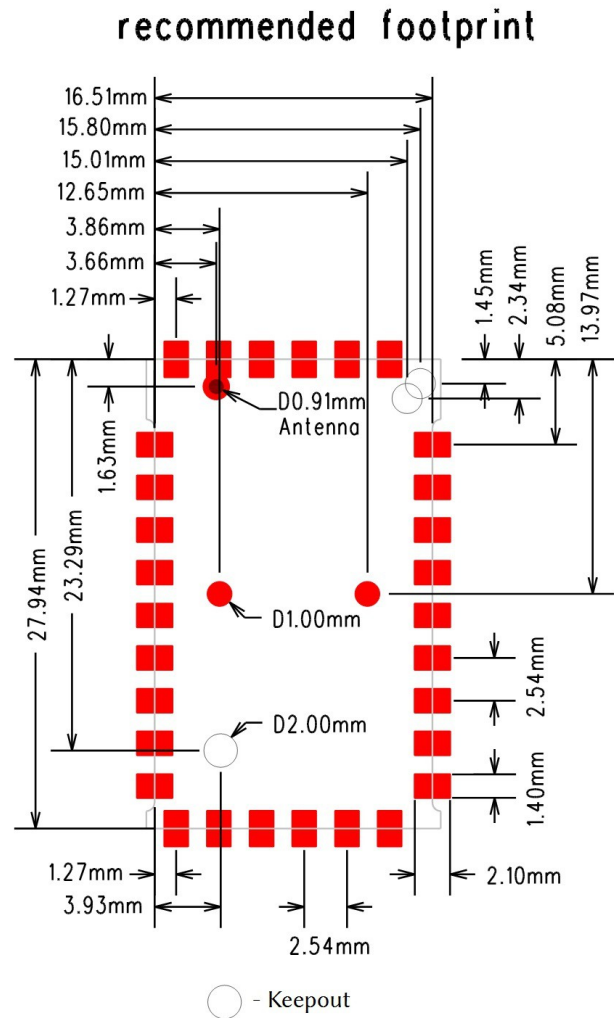
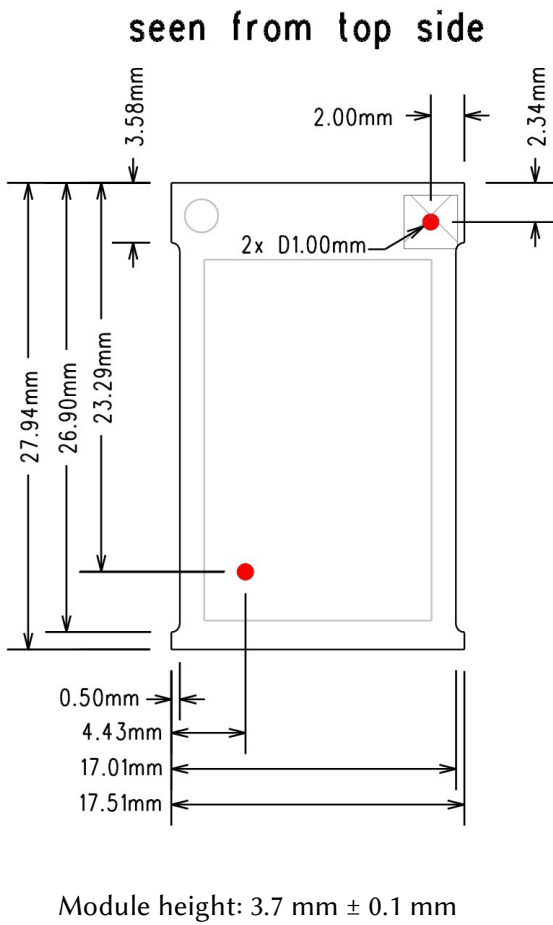

Packaging: tape & reel specification

All radino modules come in a tape & reel package suitable for pick and place machines. Small quantities are delivered as cut-tape. There are 2 kinds of reels available with 100pcs and 500pcs per reel (see section ordering information)

Except the number of modules, all parameters are same to both reel sizes:

- 13" reel size
- 44mm tape width
- tape pocket dimensions 29mm x 19mm x 4mm
- module spacing 24mm
- 2mm hole in the middle of the module body
- 1.5mm tape holes for transport

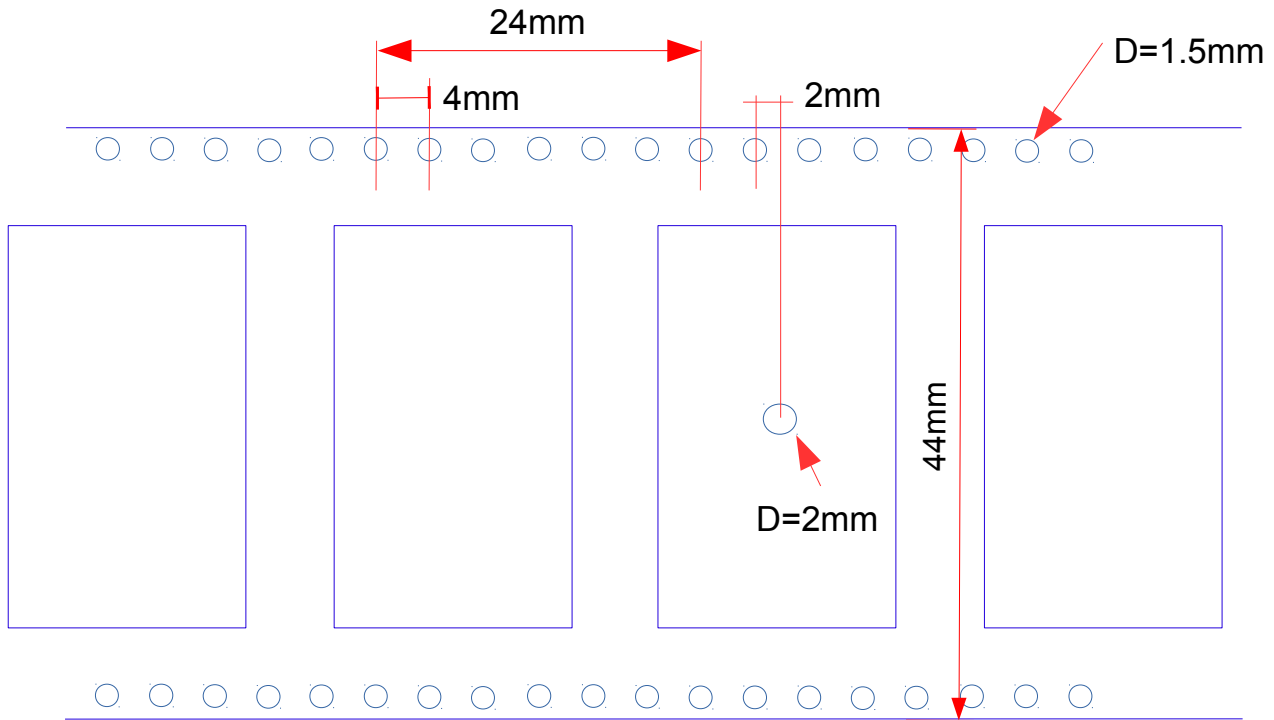

Transport direction
(Antenna connector to the right)

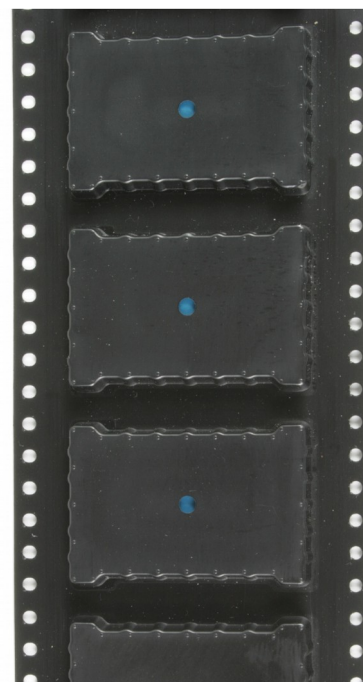

Reflow temperature profile

The single most critical stage in the automated assembly process is the reflow stage. The reflow profile shall not exceed the following maximum ratings:

- heating gradients $<3^{\circ}\text{C}/\text{sec}$
- peak zone temperature of the module $<245^{\circ}\text{C}$
- time in peak zone <40 sec.
- time above 220°C <80 sec.

Excessive temperatures, transport times and shocks during the reflow process **MUST** not be applied to the module.

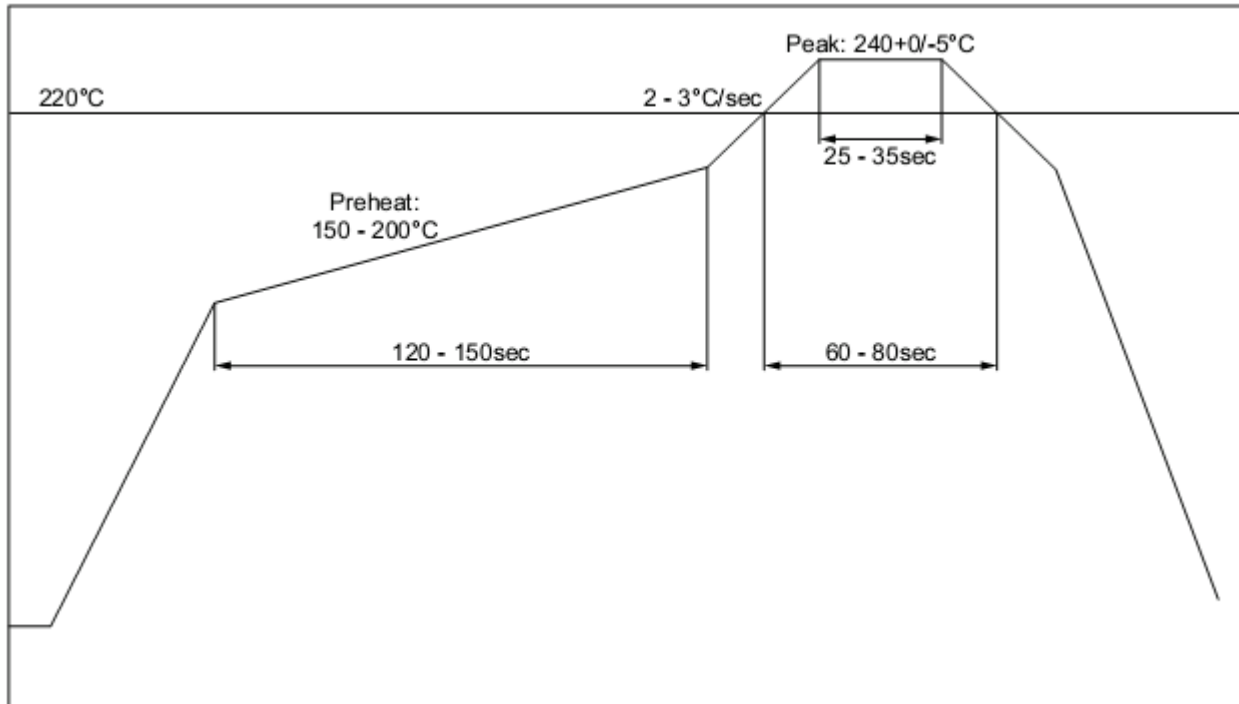

Recommended reflow temperature profile

Washability

The radino modules are wash-resistant, but are not sealed. In-Circuit recommends manufacturing without washing. If washing is needed make sure that a drying time is provided to the modules before applying electrical power. The drying time should be sufficient to allow any moisture that may have migrated into the module to evaporate, thus eliminating the potential for shorting damage during power-up or testing.

If the wash contains contaminants, the performance may be adversely affected, even after drying.

Ordering Information

Part	Ordering Code	MOQ	Package
radino32 SX1272	901.384	1	Cut Tape, Reels 100/500

All radino modules are available online: <http://www.radino.cc/>

Certifications



European R&TTE Directive Statements

The radino32 SX1272 module has been tested and found to comply with Annex IV of the R&TTE Directive 1999/5/EC and is subject of a notified body opinion. The module has been approved for Antennas with gains of 2 dBi or less.



RoHS / WEEE compliant

WEEE-Reg.-Nr. DE 17225017



Revision history:

Version	Date	Changes	Editor
A	2016/08/19		Grünig
	2017/01/26	Major Update	Grünig