

radino 32 WiFi

The In-Circuit radino 32 WiFi combines an **STM32L151** with the ESP8266EX SoC **WiFi** in a small form-factor **EMC-compliant** module.

It's part of the radino-series, which provides full-Arduino-compatible wireless communication devices in a small form factor, all **pin-compatible** to each other.



Features

- Arduino-compatible
- Wifi ESP8266EX Chip, connected internally
<http://espressif.com/en/products/esp8266/>
- easy ESP8266EX Firmware Upgrade
- 802.11 b/g/n protocol
- Wi-Fi Direct (P2P), soft-AP
- +19.5dBm transmitter power in 802.11b mode
- STM32L151CC by STMicroelectronics with 32-bit ARM® Cortex®-M3 CPU
- 256 kbyte Flash, 32 kbyte RAM, 8 kbyte EEPROM
- Low Power RTC
- 12 bit ADC and DAC
- Capacitive touch sensing supported
- 23 multifunctional GPIOs (14 PWM, 10 ADC IN, 1 DAC OUT)
- USB, I²C, SPI, 2xUSART
- Standby power consumption of <1mW (DTIM3),
- Arduino Demo Applications available in our library!

Applications

- Internet of Things (IoT)
- Mobile communications
- Digital home network
- Mobile accessories
- Data logging
- Any Arduino project



For more information visit:
<http://www.in-circuit.de/>
<http://www.radino.cc/>

Overview

The In-Circuit radino 32 WiFi combines an STM32L151 with the ESP8266EX SoC WiFi. Despite its small form factor, the radino 32 WiFi offers great connectivity. Many GPIOs and interfaces (USB, I²C, SPI, 2xUSART) of the STM32L151 can be connected to external circuitry. This makes it the perfect core for any WiFi project.

With our Arduino Library for radino 32 WiFi becomes fully Arduino-compatible, which enables easy programming, using the Arduino IDE (<http://www.arduino.cc/>).

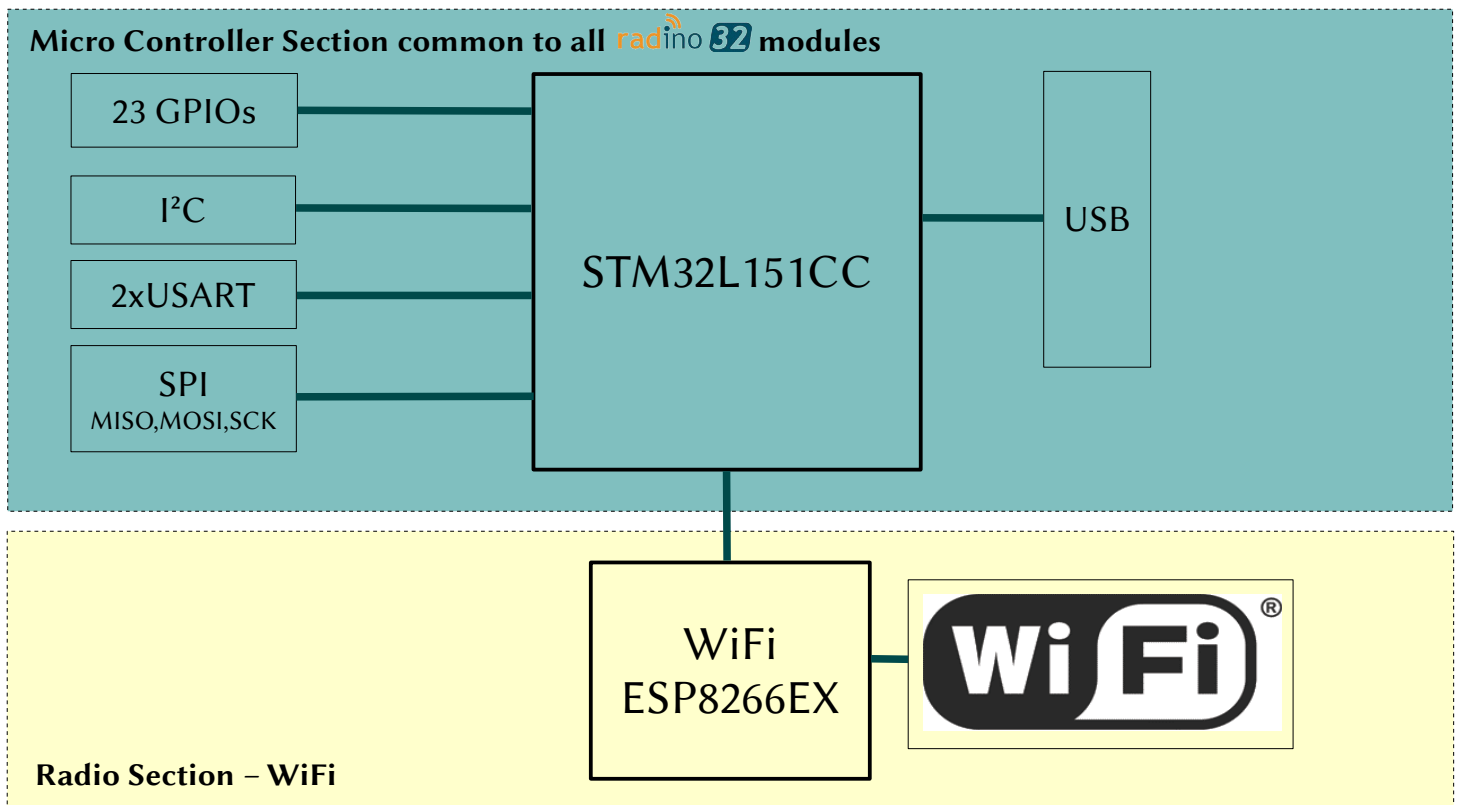
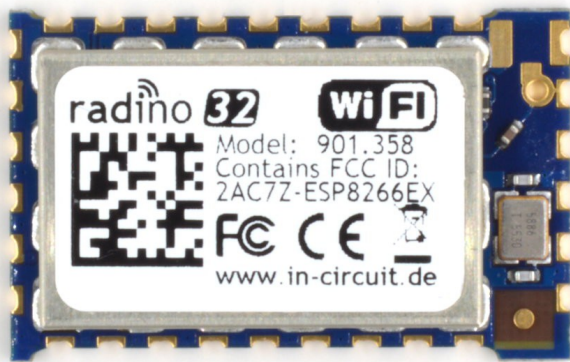

radino 32 Pinout

Connected to internal radio section:

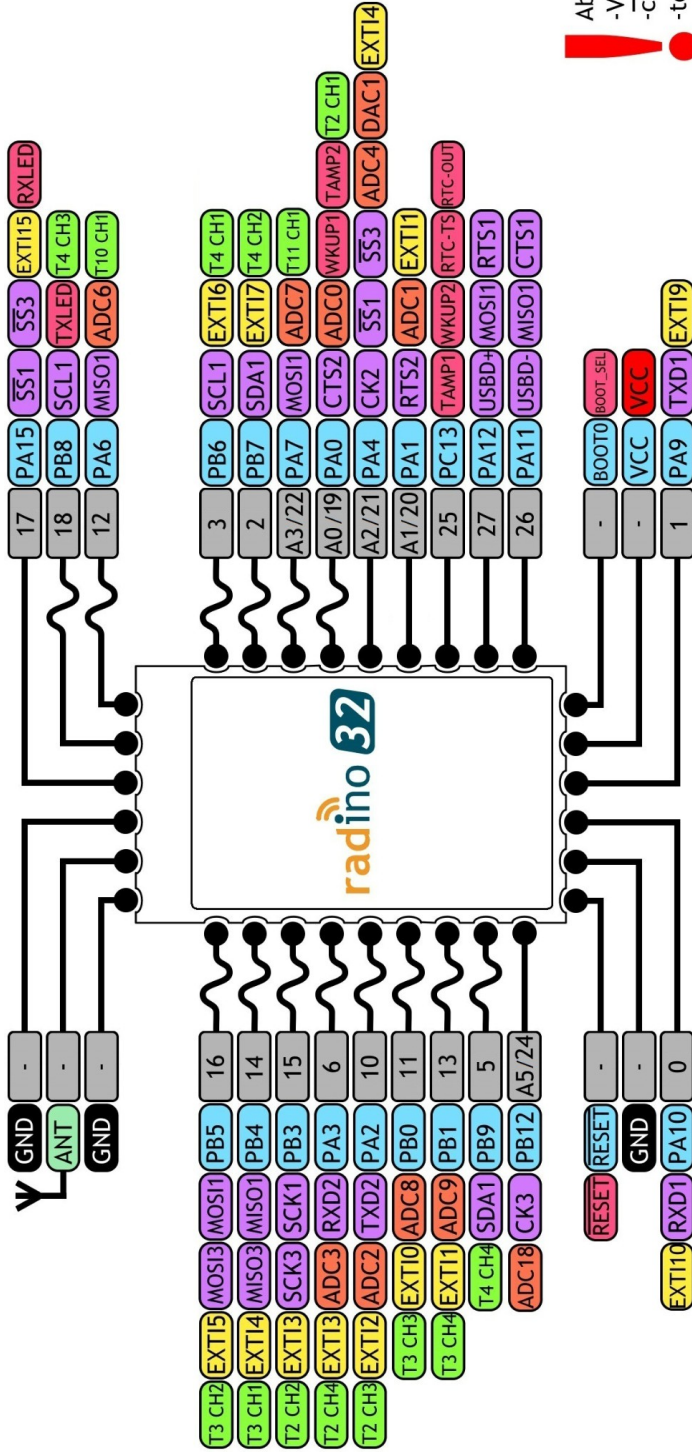
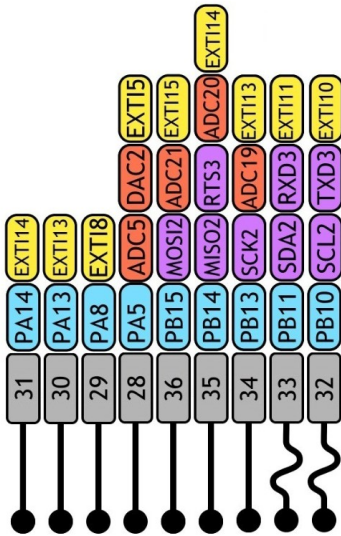

- Power
- GND
- Arduino Pin
- STM Port
- Timer Channel
- Serial Pin
- Analog Pin
- Interrupt Pin
- Control Pin
- Antenna
- PWM Pin

! Absolute max. ratings:
 -VCC: max. 3.6V
 -current per Pin max. 20mA
 -total I/O current max. 60mA

Pinout and Terminal Description



Top View

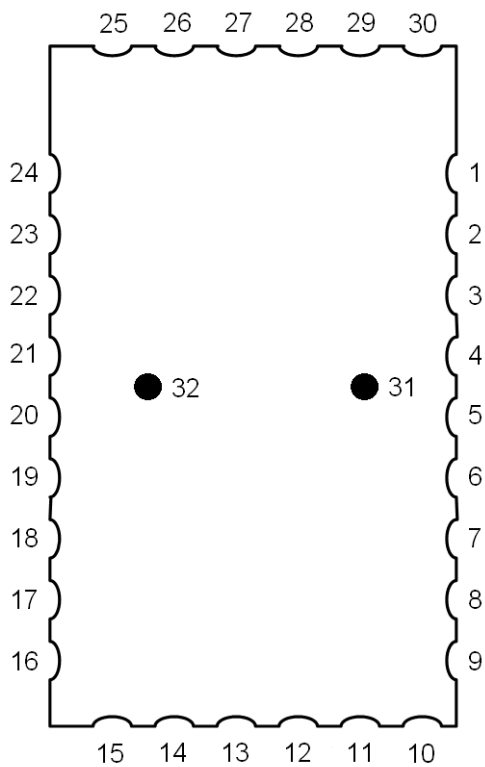
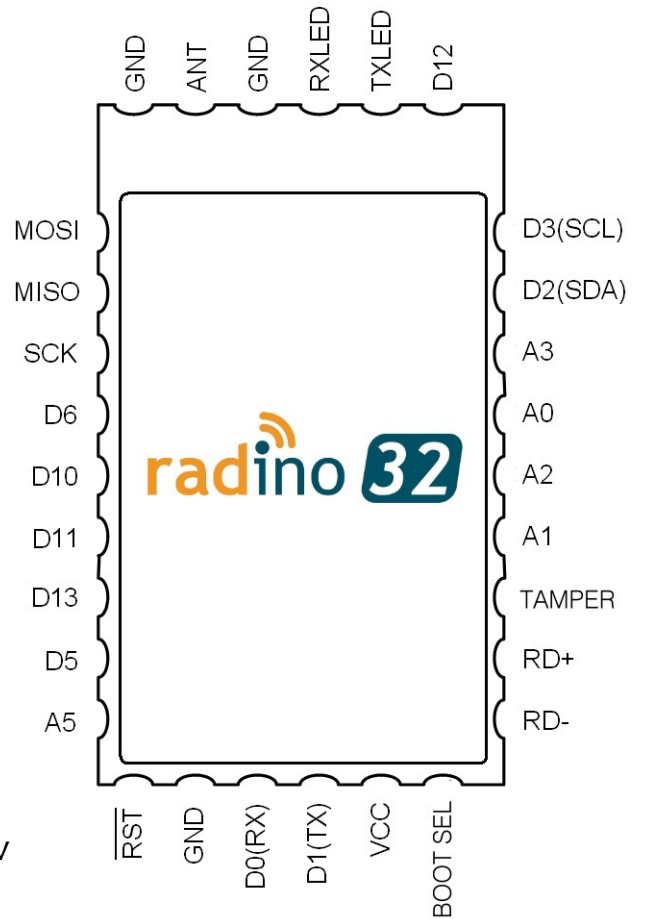

Bottom View

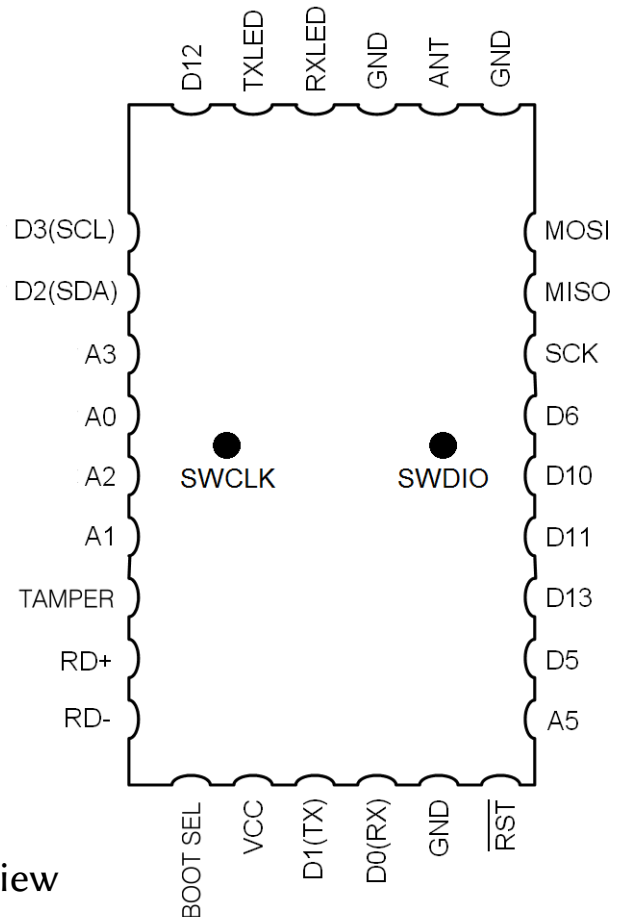

radino Pin No.	Name	Arduino Pin No.	STM32L151 CC Port	Description / Function (bold = main function)
1	MOSI	16	PB5	SPI1-MOSI SPI3-MOSI; I2C1-SMBA; PWM; TIM3-CH2; EXTI5; GPIO
2	MISO	14	PB4	SPI1-MISO SPI3-MISO; PWM; TIM3-CH1; EXTI4(shared with P20); GPIO
3	SCK	15	PB3	SPI1-SCK SPI3-SCK; PWM; TIM2-CH2; EXTI3 (shared with P4); GPIO
4	D6	6	PA3	GPIO; USART2-RX PWM; TIM2-CH4; ADC3; OPAMP1-VOUT; EXTI3 (shared with P3)
5	D10	10	PA2	GPIO; USART2-TX; PWM; TIM2-CH3; ADC2; OPAMP1-VINM; EXTI2
6	D11	11	PB0	GPIO; PWM; TIM3-CH3; ADC8; OAMP2-VOUT; EXTI0
7	D13	13	PB1	GPIO; PWM; TIM3-CH4; ADC9; EXTI1 (shared with P19)
8	D5	5	PB9	GPIO; I2C-SDA; PWM; TIM4-CH4;
9	A5	A5 24	PB12	ADC18; USART3-CK; SPI2-NSS; GPIO;
10	Reset	-	NRST	Reset of STM32L151CC
11	GND	-	VSS	Ground
12	D0(RX)	0	PA10	USART1-RX ; EXTI10; GPIO
13	D1(TX)	1	PA9	USART1-TX ; EXTI9; GPIO
14	V _{CC}	-	VCC	Power supply
15	BOOT_SELECT	-	BOOT0	Boot Select
16	RD-	26	PA11	USB-D- ; USART1-CTS; SPI1-MISO; GPIO
17	RD+	27	PA12	USB-D+ ; USART1-RTS; SPI1-MOSI; GPIO
18	TAMPER	25	PC13-WKUP2	RTC-TAMP1; WKUP2; RTC-TS; RTC-OUT; GPIO
19	A1	A1 20	PA1	ADC1; USART2-RTS; OAMP1-VINP; EXTI1(shared with P7); GPIO
20	A2	A2 21	PA4	ADC4; DAC1; USART2-CK; SPI1-NSS; SPI3-NSS; EXTI4(shared with P4); GPIO
21	A0	A0 19	PA0-WKUP1	ADC0; USART2-CTS; WKUP1; RTC-TAMP2; PWM; TIM2-CH1; GPIO
22	A3	A3 22	PA7	ADC7; SPI1-MOSI; PWM; TIM11-CH1; OPAMP2-VINM; GPIO
23	D2(SDA)	2	PB7	I2C1-SDA ; USART1-RX; PWM; TIM4-CH2; EXTI7; GPIO
24	D3(SCL)	3	PB6	I2C1-SCL ; USART1-TX; PWM; TIM4-CH1; EXTI6; GPIO
25	D12	12	PA6	GPIO; SPI1-MISO; PWM; TIM10-CH1; OPAMP2-VINP; ADC6

radino Pin No	Name	Arduino Pin No.	STM32L151 CC Port	Description / Function (bold = main function)
26	TXLED	18	PB8	TXLED ; I2C1-SCL; PWM; TIM4-CH3; GPIO
27	RXLED	17	PA15	RXLED ; SPI1-NSS; SPI3-NSS; EXTI15; GPIO
28	GND	-	VSS	Ground
29	ANTENNA	-	-	Antenna pin
30	GND	-	VSS	Ground
31	SWDIO	30	PA13	SWDIO of STM32L151CC (pad on bottom)
32	SWCLK	31	PA14	SWCLK of STM32L151CC (pad on bottom)
-	RF_EN	29	PA8	connected to internal radio section Signal: $\overline{\text{CHIP-EN}}$
-	RF_GPIO0	34	PB13	connected to internal radio section Signal: $\overline{\text{GPIO0}}$
-	RF_GPIO2	35	PB14	connected to internal radio section Signal: $\overline{\text{GPIO2}}$
-	RF_RST	36	PB15	connected to internal radio section Signal: $\overline{\text{Reset}}$
-	RF_URXD	33	PB11	connected to internal radio section Signal: RF_RXD
-	RF_UTXD	32	PB10	connected to internal radio section Signal: RF_TXD

Detailed Interconnection diagram

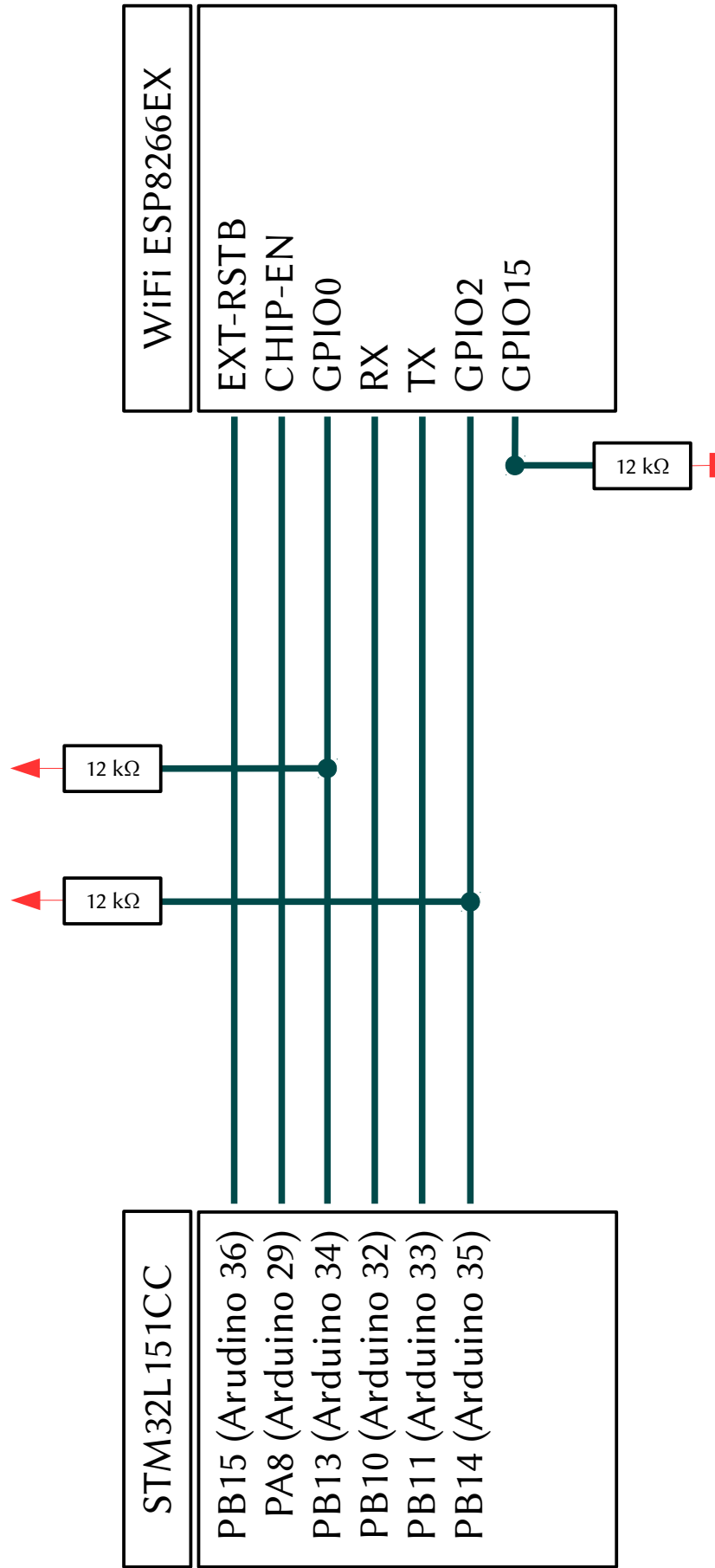

Electrical Characteristics

Absolut Maximum Ratings

Note: These are absolute maximum ratings beyond which the module can be permanently damaged. These are not maximum operating conditions.

Rating	Min	Max	Unit
Storage Temperature	-20	100	°C
V_{CC}	-0.3	3.6	V
Current per IO		20	mA
Total Current by sum of all IOs		60	mA

Recommended Operating Conditions

Environmental conditions

Rating	Min	Typ.	Max	Unit
Operating Temperature	-20		85	°C
V_{CC}	2.7	3.3	3.6	V
V_{CC} (single use of STM32L1; ESP8266EX not working below 2.7V)	1.8		3.6	V

DC Characteristics

$T_A = -20^{\circ}\text{C}$ to 85°C , $V_{CC} = 2.7\text{V}$ to 3.6V (unless otherwise noted)

Symbol	Rating	Min	Typ.	Max	Unit
V_{BS}	BOOT_SELECT Voltage	0		5.5	V
V_{IL}	Input Low Voltage,	-0.3		$0.2V_{CC}$	V
V_{IH1}	Input High Voltage, Pins: P4, P6, P7, P20	$0.9V_{CC}$		$V_{CC} + 0.3$	V
V_{IH2}	Input High Voltage, all other Pins	$0.9V_{CC}$		5.25	V
V_{OL}	Output Low Voltage			0.5	V
V_{OH}	Output High Voltage	$0.9V_{CC}$			V

Current consumption parameters

Operation conditions: $V_{CC}=3.3V$, $T_A=25^{\circ}C$.

Symbol	Rating	Min	Typ.	Max	Unit
I_{on}	Full on	---	40	300	mA
I_{lp}	Low-power mode (ESP:Power save mode DTIM 3; STM:Low-power run mode)	---	1	---	mA
I_{ds}	Deep-sleep mode (ESP: Deep sleep mode; STM: Low-power sleep mode)	---	15	---	μA
I_{s1}	Standby mode with RTC (ESP: Total shutdown; STM: Standby mode, RTC clocked by LSE)	---	1.8	---	μA
I_{s2}	Standby without RTC (ESP: Total shutdown; STM: Standby mode, RTC disabled, wakeup by radino pin 18 or 21)	---	1	---	μA

Package Dimensions and recommended PCB Footprint

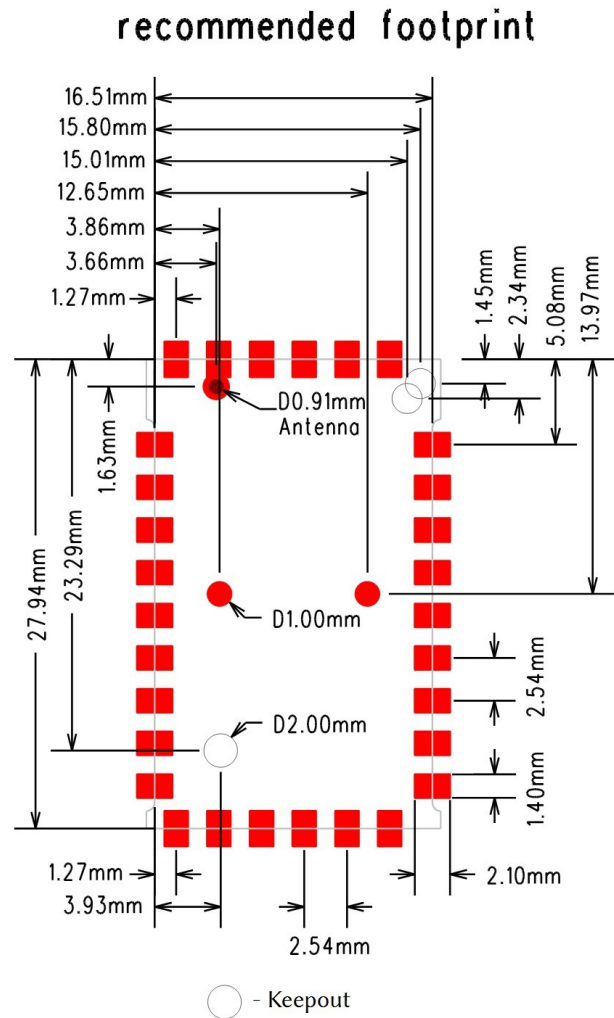
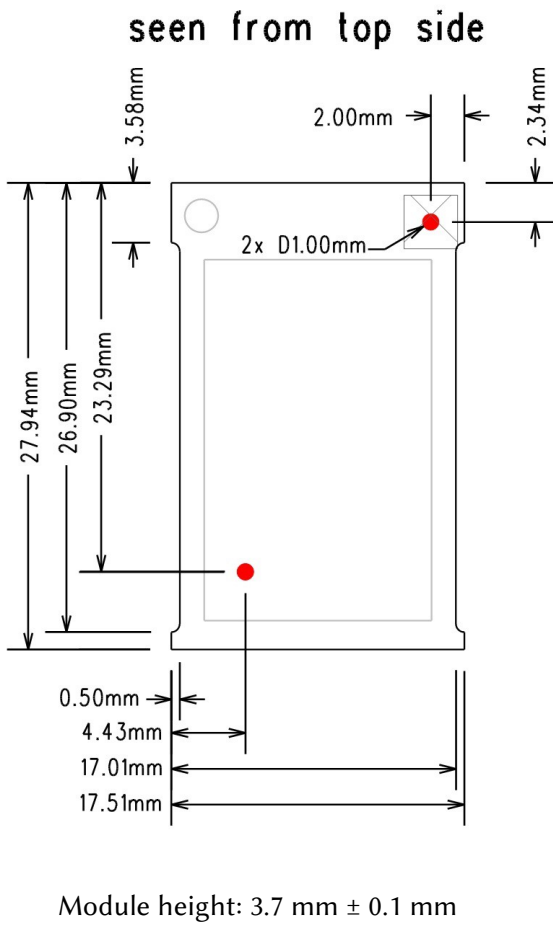

Packaging: tape & reel specification

All radino modules come in a tape & reel package suitable for pick and place machines. Small quantities are delivered as cut-tape. There are 2 kinds of reels available with 100pcs and 500pcs per reel (see section ordering information)
 Except the number of modules, all parameters are same to both reel sizes:

- 13" reel size
- 44mm tape width
- tape pocket dimensions 29mm x 19mm x 4mm
- module spacing 24mm
- 2mm hole in the middle of the module body
- 1.5mm tape holes for transport

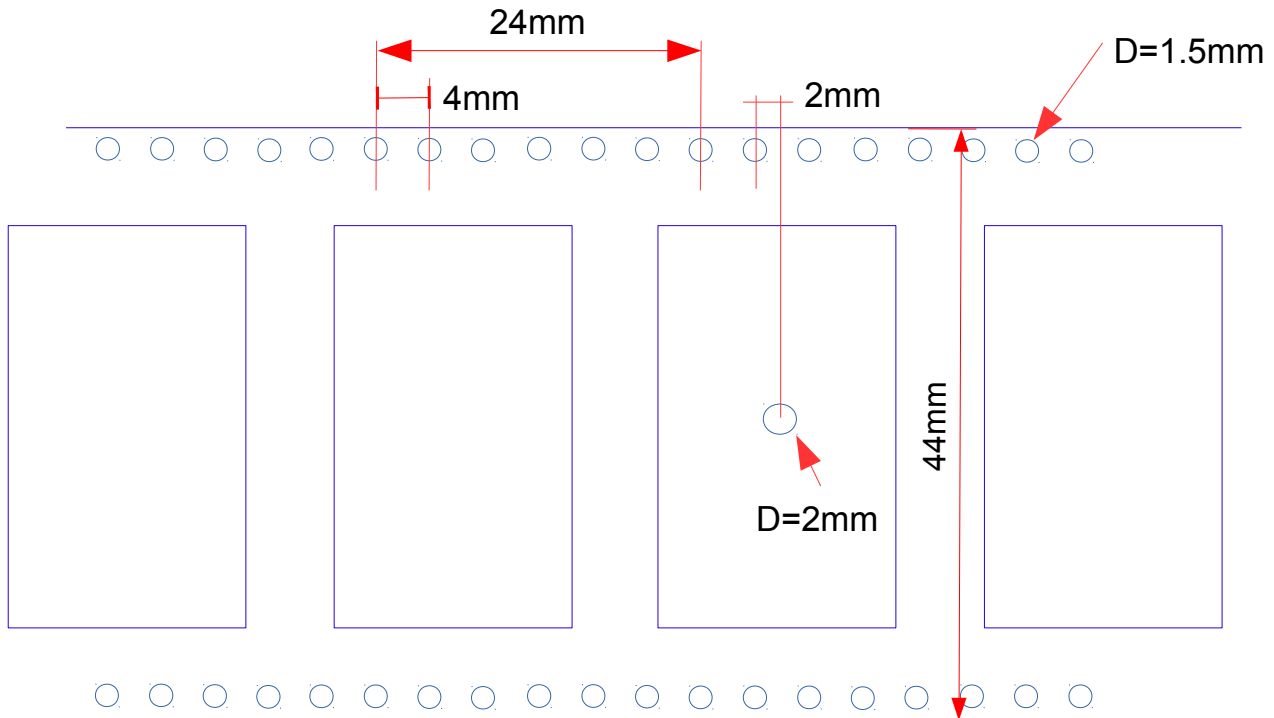

Transport direction
 (Antenna connector to the right)

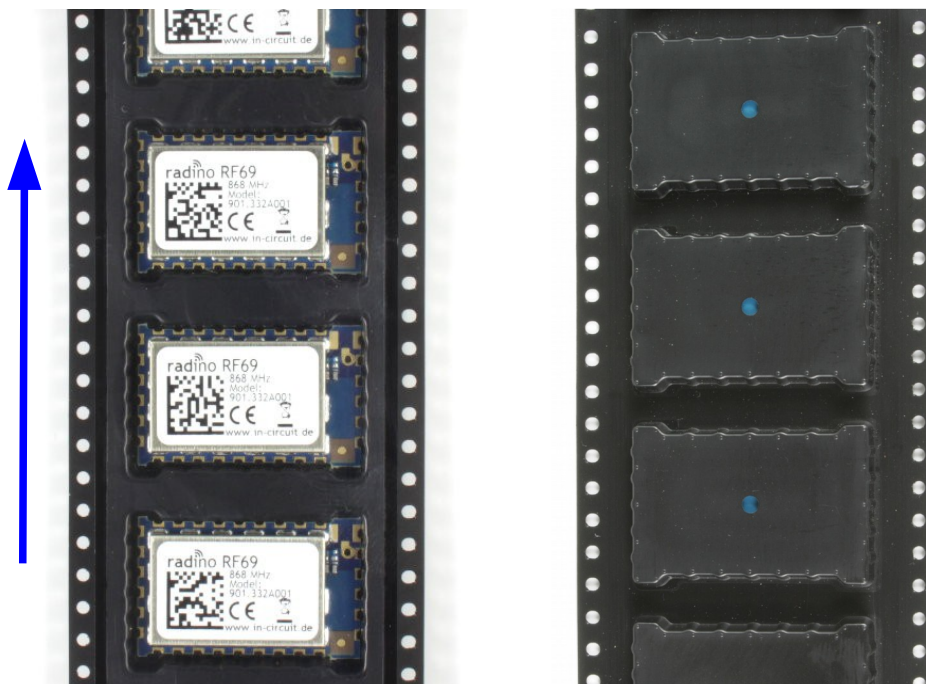

Reflow temperature profile

The single most critical stage in the automated assembly process is the reflow stage. The reflow profile shall not exceed the following maximum ratings:

- heating gradients <math><3^{\circ}\text{C}/\text{sec}</math>
- peak zone temperature of the module <math><245^{\circ}\text{C}</math>
- time in peak zone <math><40\text{ sec.}</math>
- time above 220°C <math><80\text{ sec.}</math>

Excessive temperatures, transport times and shocks during the reflow process **MUST** not be applied to the module.

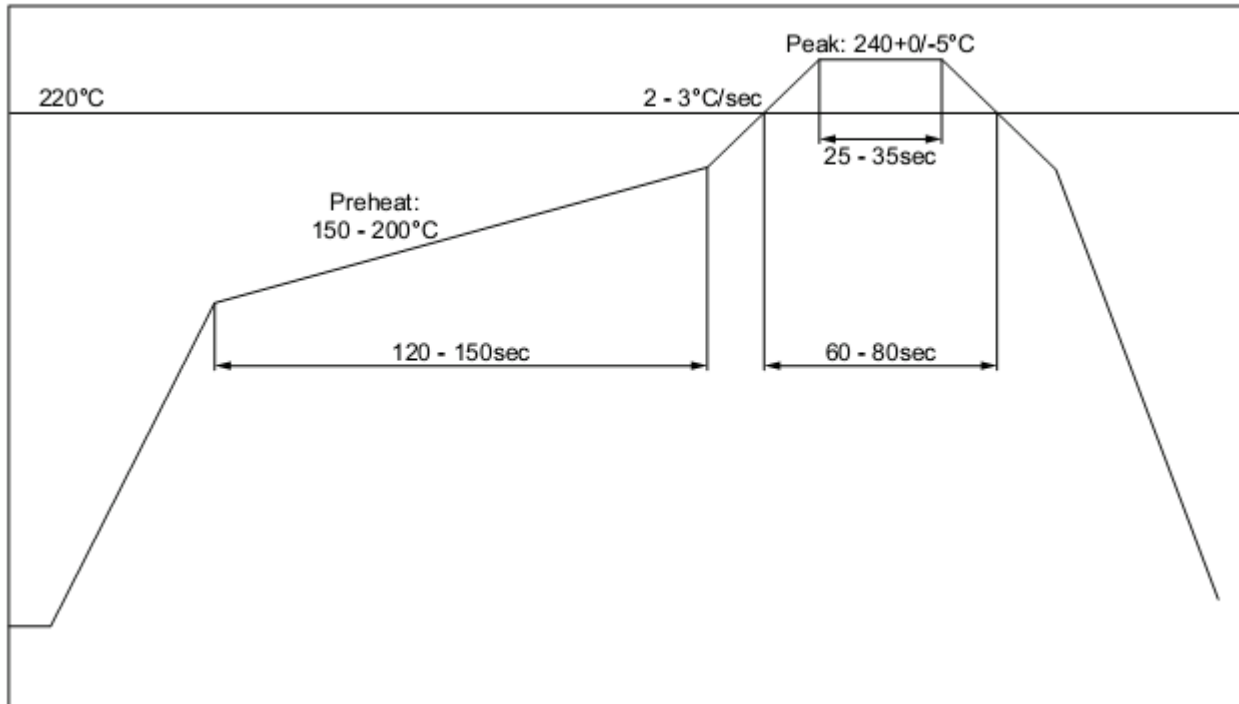

Recommended reflow temperature profile

Washability

The radino modules are wash-resistant, but are not sealed. In-Circuit recommends manufacturing without washing. If washing is needed make sure that a drying time is provided to the modules before applying electrical power. The drying time should be sufficient to allow any moisture that may have migrated into the module to evaporate, thus eliminating the potential for shorting damage during power-up or testing.

If the wash contains contaminants, the performance may be adversely affected, even after drying.

Ordering Information

Part	Ordering Code	MOQ	Package
radino32 WiFi	901.358	1	Cut Tape, Reels 100/500

All radino modules are available online: <http://www.radino.cc/>

Certifications



European R&TTE Directive Statements

The radino32 WiFi module has been tested and found to comply with Annex IV of the R&TTE Directive 1999/5/EC and is subject of a notified body opinion. The module has been approved for Antennas with gains of 2 dBi or less.



Federal Communication Commission Certification Statements

In order to retain compliance with the FCC certification requirements, the following conditions must be met:

1. Modules must be installed by original equipment manufacturers (OEM) only.
2. The module must only be operated with antennas at a gain of 2 dBi max.
3. The OEM must place a clearly visible text label on the outside of the end-product containing the text "Contains FCC ID: 2AC7Z-ESP8266EX"

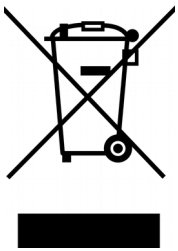

RoHS / WEEE compliant

WEEE-Reg.-Nr. DE 17225017

Revision history:

Version	Date	Changes	Editor
A	2015/04/09		Klause
	2017/01/23	Major Update	Grünig