

radino 32 CC1101

The In-Circuit radino 32 CC1101 combines an STM32L1 with the CC1101 RF Transceiver in a small form-factor EMC-compliant module.

It's part of the radino-series, which provides full-Arduino-compatible wireless communication devices in a small form factor, all pin-compatible to each other.



Features

- Arduino-compatible
- RF Transceiver CC1101 connected internally <http://www.ti.com/lit/ds/symlink/cc1101.pdf>
- Wide range of possible protocols
- Available for 433MHz / 868MHz / 915MHz (assembly option for BALUN)
- STM32L151CC by STMicroelectronics with 32-bit ARM® Cortex®-M3 CPU
- 256 kbyte Flash, 32 kbyte RAM, 8 kbyte EPROM
- Low Power RTC
- 12 bit ADC and DAC
- Capacitive touch sensing supported
- 23 multifunctional GPIOs (15 PWM, 10 ADC IN, 1 DAC OUT)
- USB, I²C, 2xSPI, 2xUSART

Applications

- Ultra low power wireless applications operating in the 433/868/915 MHz ISM/SRD bands
- Wireless alarm and security systems
- Industrial monitoring and control
- Wireless sensor networks
- AMR – Automatic Meter Reading
- Home and building automation
- Wireless MBUS

For more information visit:
<http://www.in-circuit.de/>
<http://www.radino.cc/>



radino 32 Pinout

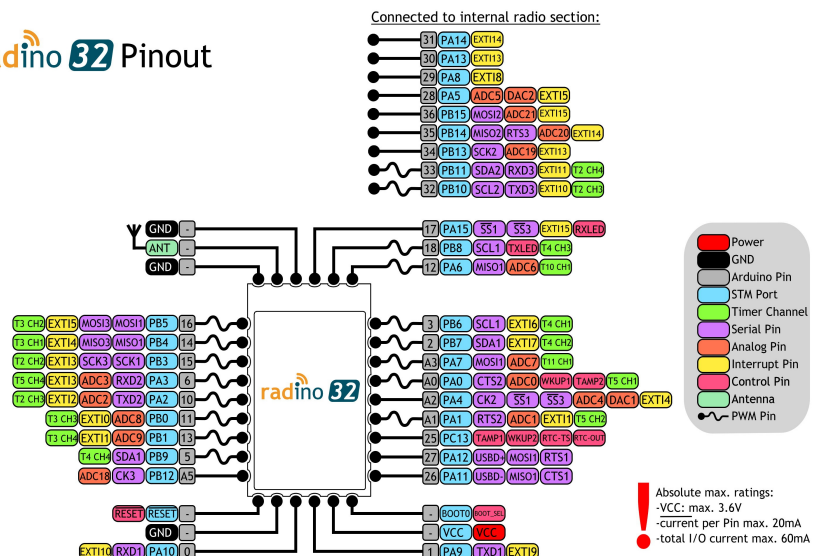

Overview

The In-Circuit radino 32 CC1101 combines an STM32L151 with the CC1101 RF Transceiver. Despite its small form factor, the radino 32 CC1101 offers great connectivity. Many GPIOs and interfaces (USB, I²C, 2xSPI, 2xUSART) of the STM32L151 can be connected to external circuitry.

With our Arduino Library for radino the radino 32 CC1101 becomes fully Arduino-compatible, which enables easy programming, using the Arduino IDE (<http://www.arduino.cc/>).

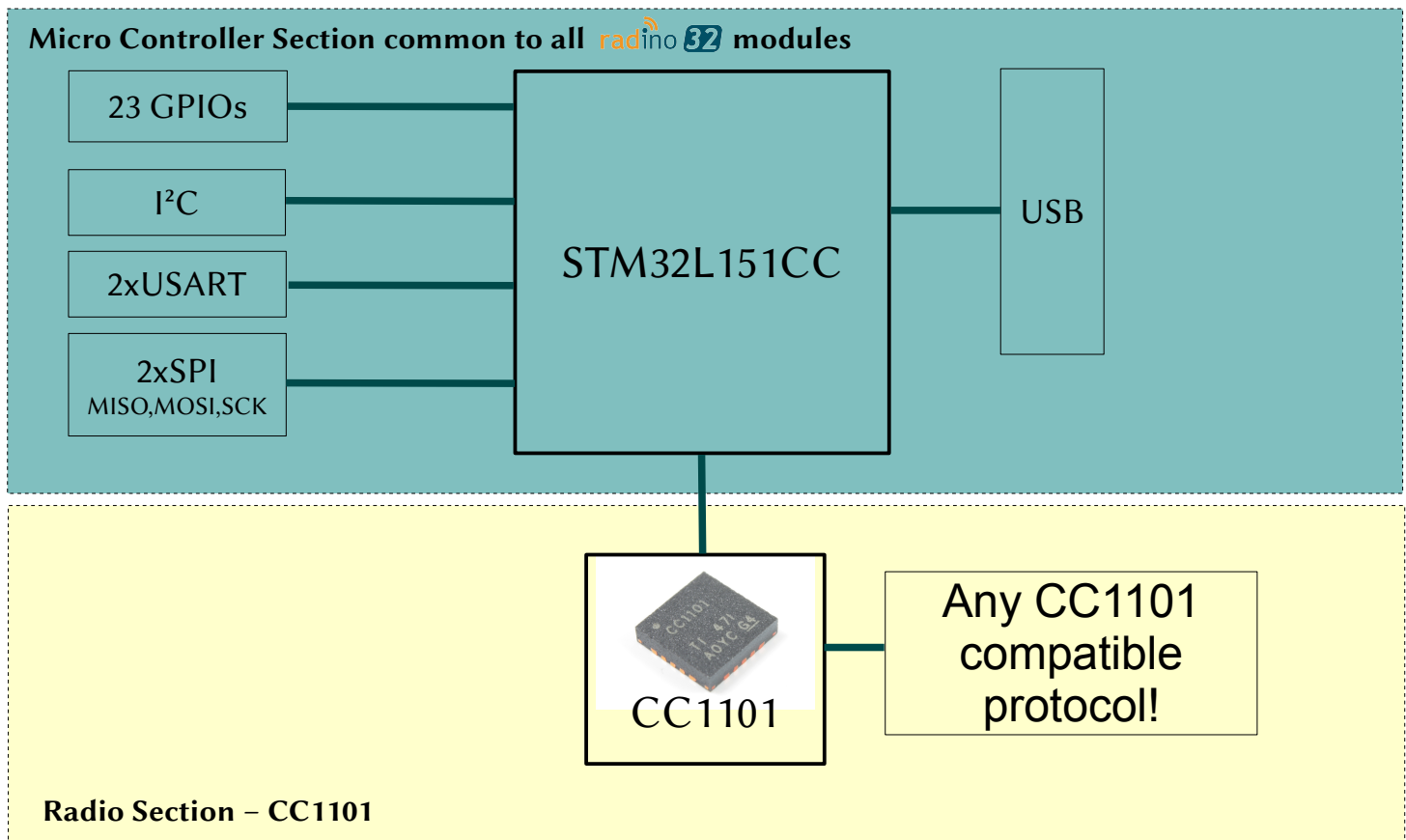

Pinout and Terminal Description



Top View

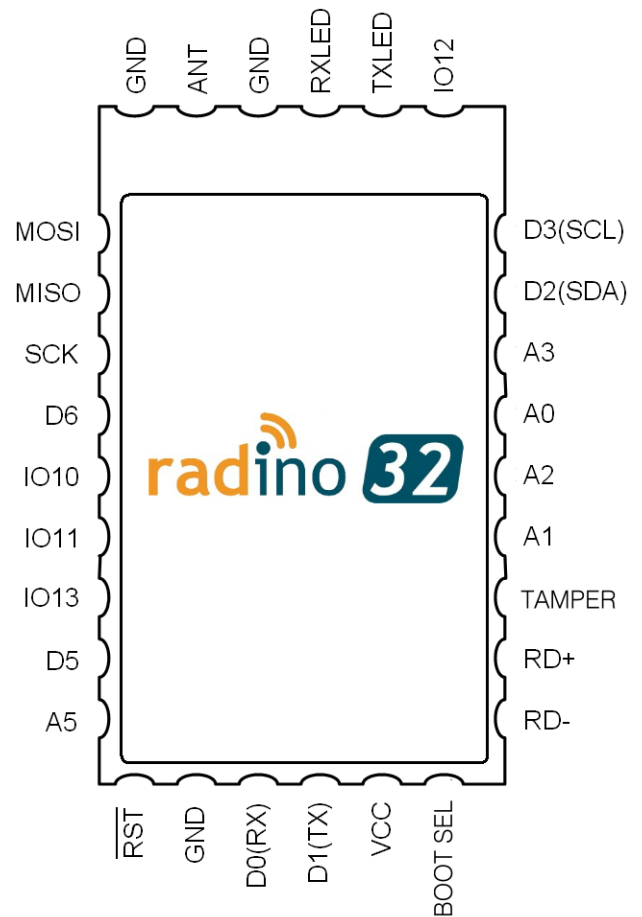

radino Pin No.	Name	Arduino Pin No.	STM32L151 CC Port	Description / Function (bold = main function)
1	MOSI	16	PB5	SPI1-MOSI SPI3-MOSI; I2C1-SMBA; PWM; TIM3-CH2; EXTI5; GPIO
2	MISO	14	PB4	SPI1-MISO SPI3-MISO; PWM; TIM3-CH1; EXTI4(shared with P20); GPIO
3	SCK	15	PB3	SPI1-SCK SPI3-SCK; PWM; TIM2-CH2; EXTI3 (shared with P4); GPIO
4	D6	6 A7	PA3	GPIO; USART2-RX PWM; TIM5-CH4; ADC3; OPAMP1-VOUT; EXTI3 (shared with P3)
5	IO10	10 A10	PA2	GPIO; USTAR2-TX; PWM; TIM2-CH3; ADC2; OPAMP1-VINM; EXTI2
6	IO11	11	PB0	GPIO; PWM; TIM3-CH3; ADC8; OAMP2-VOUT; EXTI0
7	IO13	13	PB1	GPIO; PWM; TIM3-CH4; ADC9; EXTI1 (shared with P19)
8	D5	5	PB9	GPIO; I2C-SDA; PWM; TIM4-CH4;
9	A5	A5 23	PB12	ADC18; USATR3-CK; SPI2-NSS; GPIO;

radino Pin No	Name	Arduino Pin No.	STM32L151 CC Port	Description / Function (bold = main function)
10	Reset	-	NRST	Reset of STM32L151CC
11	GND	-	VSS	Ground
12	D0(RX)	0	PA10	USART1-RX ; EXT110; GPIO
13	D1(TX)	1	PA9	USART1-TX ; EXT19; GPIO
14	V _{CC}	-	VCC	Power supply
15	BOOT_SELECT	-	BOOT0	Boot Select
16	RD-	26	PA11	USB-D- ; USART1-CTS; SPI1-MISO; GPIO
17	RD+	27	PA12	USB-D+ ; USATR1-RTS; SPI1-MOSI; GPIO
18	TAMPER	25	PC13-WKUP2	RTC-TAMP1; WKUP2; RTC-TS; RTC-OUT; GPIO
19	A1	A1 19	PA1	ADC1; USART2-RTS; OAMP1-VINP; PWM; TIM5-CH2; EXT11(shared with P7); GPIO
20	A2	A2 20	PA4	ADC4; DAC1; USART2-CK; SPI1-NSS; SPI3-NSS; EXT14(shared with P4); GPIO
21	A0	A0 18	PA0-WKUP1	ADC0; USART2-CTS; WKUP1; RTC-TAMP2; PWM; TIM5-CH1; GPIO
22	A3	A3 21	PA7	ADC7; SPI1-MOSI; PWM; TIM11-CH1; OPAMP2-VINM; GPIO
23	D2(SDA)	2	PB7	I2C1-SDA ; USATR1-RX; PWM; TIM4-CH2; EXT17; GPIO
24	D3(SCL)	3	PB6	I2C1-SCL ; USART1-TX; PWM; TIM4-CH1; EXT16; GPIO
25	IO12	12 A11	PA6	GPIO; SPI1-MISO; PWM; TIM10-CH1; OPAMP2-VINP; ADC6
26	TXLED	18	PB8	TXLED ; I2C1-SCL; PWM; TIM4-CH3; GPIO
27	RXLED	17	PA15	RXLED ; SPI1-NSS; SPI3-NSS; EXT115; GPIO
28	GND	-	VSS	Ground
29	ANTENNA	-	-	Antenna pin
30	GND	-	VSS	Ground
-	RF_MISO	35	PB14	connected to internal radio section Signal: SO
-	RF_MOSI	36	PB15	connected to internal radio section Signal: SI
-	RF_SCK	34	PB13	connected to internal radio section Signal: SCLK
-	RF_SS	33	PB11	connected to internal radio section Signal: \overline{CS}
-	RF_RDY	30	PA13	connected to internal radio section Signal: GDO2
-	RF_ACT	29	PA8	connected to internal radio section Signal: GDO0
-	FREQ_SEL	28	PA5	0 Ω Pulldown-resistor in 433MHz version 10k Ω Pullup-restistor in 868MHz version

Detailed Interconnection diagram

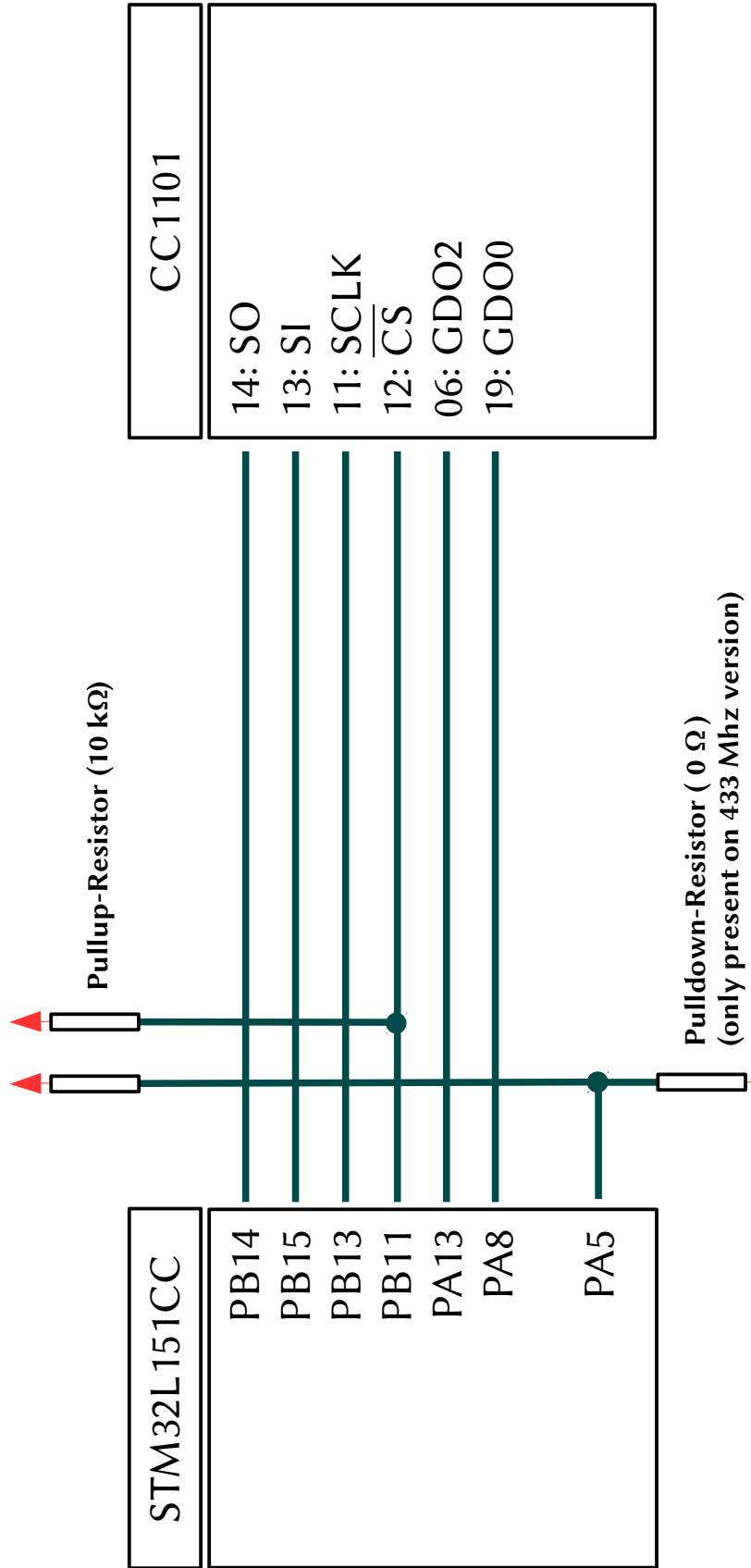

Pin number: Pin description

Portname

Electrical Characteristics

Absolut Maximum Ratings

Note: These are absolute maximum ratings beyond which the module can be permanently damaged. These are not maximum operating conditions.

Rating	Min	Max	Unit
Storage Temperature	-40	125	°C
V_{CC}	-0.3	3.6	V
Current per IO		20	mA
Total Current by sum of all IOs		60	mA

Recommended Operating Conditions

Environmental conditions

Rating	Min	Typ.	Max	Unit
Operating Temperature	-40		85	°C
V_{CC}	1.8	3.3	3.6	V

DC Characteristics

$T_A = -40^{\circ}\text{C}$ to 85°C , $V_{CC} = 2.7\text{V}$ to 3.6V (unless otherwise noted)

Symbol	Rating	Min	Typ.	Max	Unit
V_{BS}	BOOT_SELECT Voltage	0		5.5	V
V_{IL}	Input Low Voltage,	-0.3		$0.2V_{CC}$	V
V_{IH1}	Input High Voltage, Pins: P4, P6, P7, P20	$0.9V_{CC}$		$V_{CC} + 0.3$	V
V_{IH2}	Input High Voltage, all other Pins	$0.9V_{CC}$		5.25	V
V_{OL}	Output Low Voltage			0.5	V
V_{OH}	Output High Voltage	$0.9V_{CC}$			V

Current consumption parameters

Operation conditions: $V_{CC}=3.3V$, $T_A=-40^{\circ}C$ to $+85^{\circ}C$.

Symbol	Rating	Min	Typ.	Max	Unit
I_{on}	Full on	---	20	---	mA
I_{lp}	Low-power transmit mode (CC1101: Low power transmit, $P_{out}=-6dBm$; STM: Low-power run mode)	---	18	---	mA
I_{sb}	Low-power sleep mode (nRF: RX polling; STM: Low-power sleep mode)	---	18	---	μA
I_{s1}	Standby mode with RTC (CC1101: power down mode; STM: Standby mode, RTC clocked by LSE)	---	1.4	---	μA
I_{s2}	Standby without RTC (CC1101: power down mode; STM: Standby mode, RTC disabled, wakeup by radino pin 18 or 21)	---	0.5	---	μA

Package Dimensions and recommended PCB Footprint

seen from top side

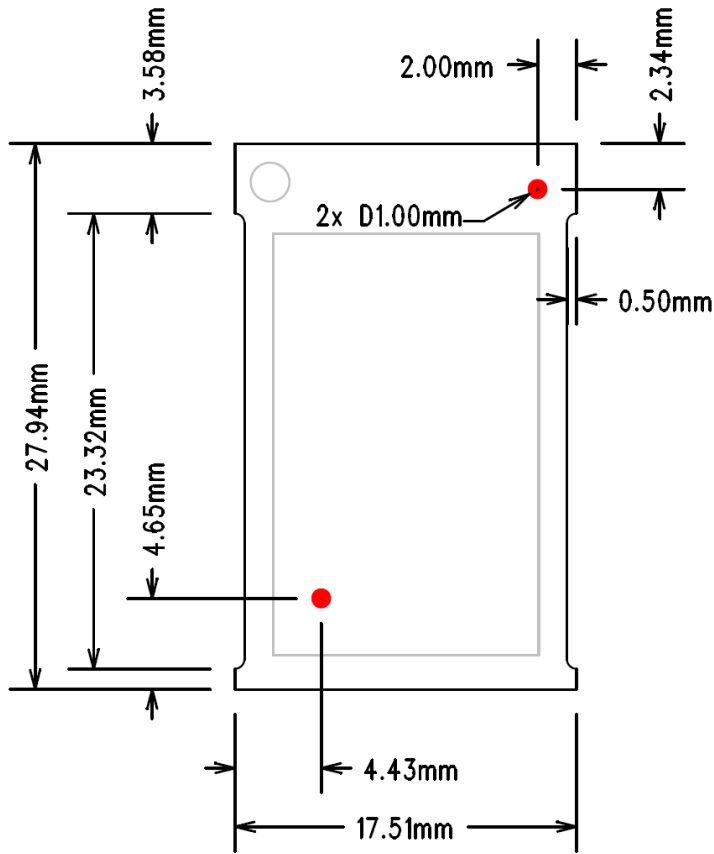

recommended footprint

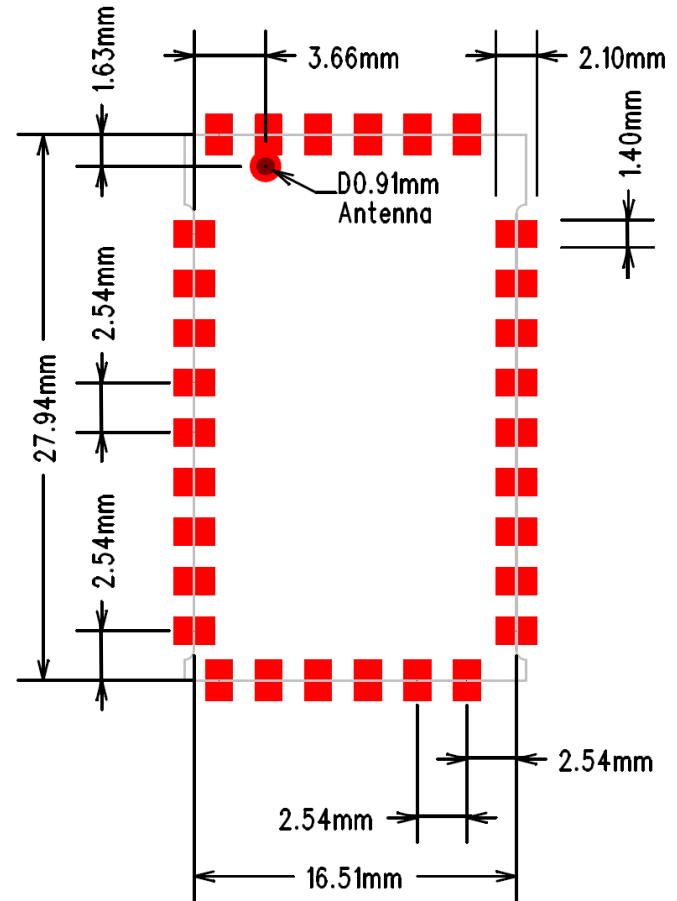

Packaging: tape & reel specification

All radino modules come in a tape & reel package suitable for pick and place machines. Small quantities are delivered as cut-tape. There are 2 kinds of reels available with 100pcs and 500pcs per reel (see section ordering information)

Except the number of modules, all parameters are same to both reel sizes:

- 13" reel size
- 44mm tape width
- tape pocket dimensions 29mm x 19mm x 4mm
- module spacing 24mm
- 2mm hole in the middle of the module body
- 1.5mm tape holes for transport

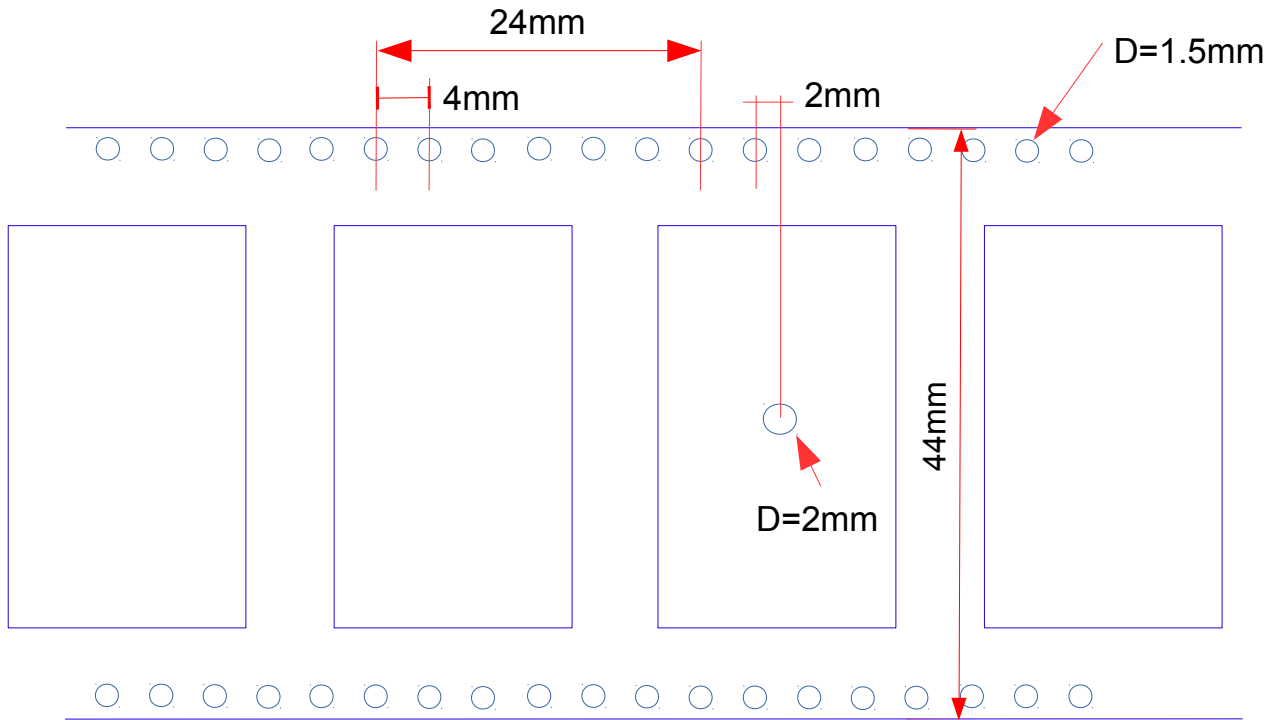

Transport direction
(Antenna connector to the right)

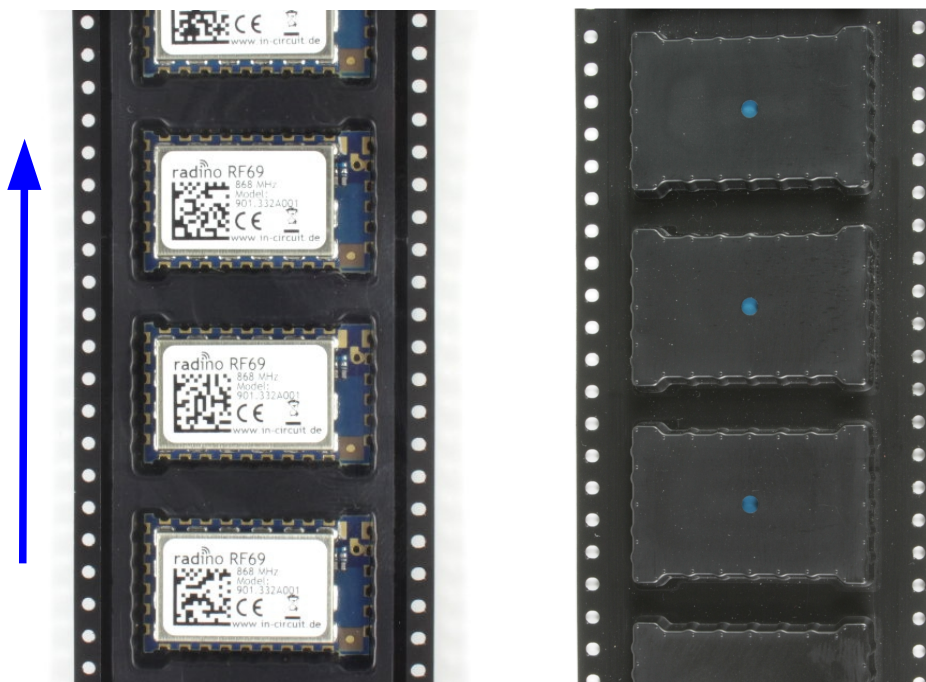

Reflow temperature profile

The single most critical stage in the automated assembly process is the reflow stage. The reflow profile shall not exceed the following maximum ratings:

- heating gradients $<3^{\circ}\text{C}/\text{sec}$
- peak zone temperature of the module $<245^{\circ}\text{C}$
- time in peak zone <40 sec.
- time above 220°C <80 sec.

Excessive temperatures, transport times and shocks during the reflow process **MUST** not be applied to the module.

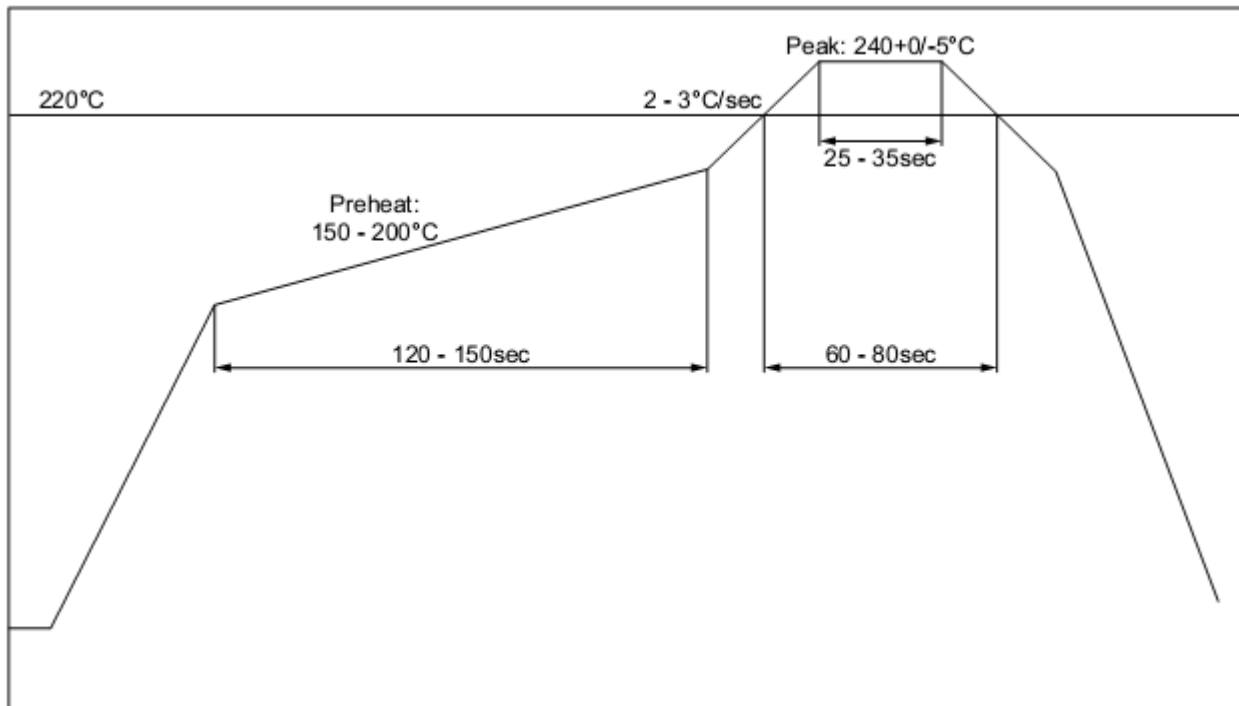

Recommended reflow temperature profile

Washability

The radino modules are wash-resistant, but are not sealed. In-Circuit recommends manufacturing without washing. If washing is needed make sure that a drying time is provided to the modules before applying electrical power. The drying time should be sufficient to allow any moisture that may have migrated into the module to evaporate, thus eliminating the potential for shorting damage during power-up or testing.

If the wash contains contaminants, the performance may be adversely affected, even after drying.

Ordering Information

Part	Ordering Code	MOQ	Package
radino32 CC1101 433 MHz	901.356	1	Cut Tape, Reels 100/500
radino32 CC1101 868 MHz	901.356A001	1	Cut Tape, Reels 100/500

All radino modules are available online: <http://www.radino.cc/>

Certifications



European R&TTE Directive Statements

The radino32 CC1101 module has been tested and found to comply with Annex IV of the R&TTE Directive 1999/5/EC and is subject of a notified body opinion. The module has been approved for Antennas with gains of 2 dBi or less.



RoHS / WEEE compliant

WEEE-Reg.-Nr. DE 17225017



Revision history:

Version	Date	Changes	Editor
A	2015/05/18		Klause